

4650-PM

PM-CEMS • PM-CPMS



● PS-11 Continuous Particulate Matter Measurement



LAND[®]
AMETEK[®]



QUALITY CUSTOMER SOLUTIONS

4650-PM

AMETEK LAND HAS BEEN MANUFACTURING PRECISION MEASURING EQUIPMENT SINCE 1947.

WE ARE SPECIALISTS IN NON-CONTACT TEMPERATURE MEASUREMENT AND COMBUSTION MONITORING WITH APPLICATIONS ACROSS DIVERSE INDUSTRIES SUCH AS STEEL AND GLASS MAKING, POWER GENERATION AND CEMENT MANUFACTURE.

As part of AMETEK Process & Analytical Instruments Division since 2006, our customers benefit from the worldwide AMETEK sales and service team.

THE 4650-PM PROVIDES ACCURATE AND RELIABLE MEASUREMENT OF PARTICULATE MATTER.

The Model 4650-PM uses an improved forward scatter technique to measure particulate matter in stacks and ducts. It features an improved optical system and lower angle of incidence than competing systems, resulting in a lower detection limit and better stability.

The rugged and reliable design is ideal for applications in electricity generation, industrial boilers, glass, cement and metals. It can be installed after a baghouse or electrostatic precipitator.

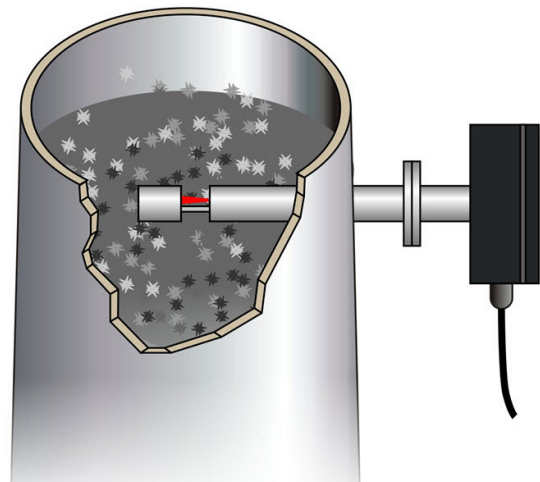

FEATURES ▼

Large area collection optics

Low angle forward-scatter measurement

Wide measurement range

No moving parts in measurement path

Wide temperature range

Built-in data log

Regulatory compliance

RS485, 4-20 mA outputs

BENEFITS ▼

Better detection limit

Reduced sensitivity to particle size

Measures concentrations from 0.01 to 200 mg/m³

Highest stability and reliability

Standard temperatures up to 250 °C (480 °F)
High temperature option up to 500 °C (930 °F)

Improved data security and troubleshooting

EPA PS-11, MATS, Boiler MACT; can be used as PM-CEMS or PM-CPMS

Maximum flexibility and connectivity

THE MODEL 4650-PM IS A RUGGED, RELIABLE AND VERY ACCURATE PM-CEMS FOR APPLICATIONS WHERE CONDENSED WATER IS NOT PRESENT.

SPECIFICATION & DESIGN

FORWARD SCATTER

As particles travel through the laser beam, they scatter light in all directions. The strongest scattering is in the forward direction.

NO MOVING PARTS IN MEASUREMENT PATH

The optical path is fixed for maximum stability and reliability. The only moving part is the automatic calibration device.

CALIBRATION CHECK

Automatic check of zero and upscale calibration.

PM-CEMS OR PM-CPMS

The 4650-PM can be used as either a continuous emissions monitor (PM-CEMS) or as a continuous parametric monitor (PM-CPMS).

WIDE TEMPERATURE RANGE

There are no delicate components in the stack, so the Model 4650-PM can be used in temperatures up to 500 °C (930°F).

CALIBRATION AUDIT

Filter audit units allow for periodic linearity checks.

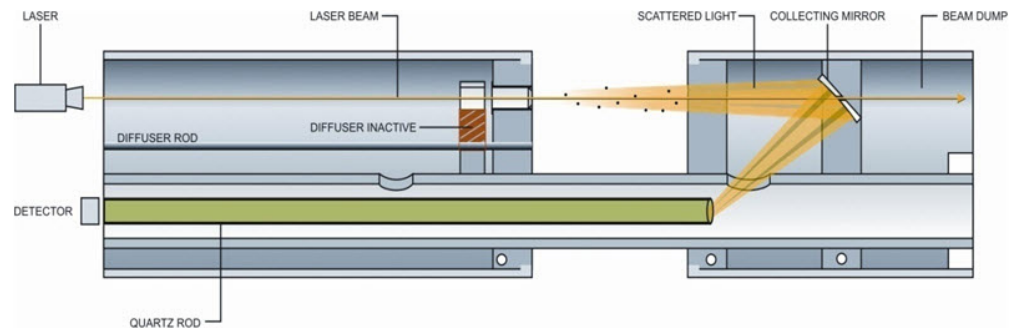

TEMPERATURES UP TO 500 °C (930 °F)

CONTROL UNITS

The Model 4650-PM comprises a stack-mounted probe and a separate control unit which provides power and communications as well as a user-interface.

Two control units are available. The Single controller supports one probe and has a single 4-20 mA output. The Multi controller supports multiple probes and provides four 4-20 mA outputs.



APPLICATIONS

THE 4650-PM CAN BE USED TO MEASURE PM IN ALL COMBUSTION PROCESSES WHERE CONDENSED WATER IS NOT PRESENT

- Electricity Generating Units
- Industrial Boilers
- Glass Works
- Cement Plant
- Metals Refining
- Process Heaters

4650-PM

PM-CEMS

SPECIFICATIONS

Measuring Probe

Measuring Technique:	Forward-scatter Optical Detection
Light Source:	Diode Laser 650 nm. Class 3R
Measurement Range:	0-15mg / m ³ to 0-200 mg / m ³
Detection Limit:	< 0.1 mg / m ³
Operating Temperature:	-20 °C to 50 °C / -4 °F to 122 °F
Max. Flue Gas Temperature:	250 °C (480 °F) standard; 500 °C (930 °F) with high temperature option
Insertion Depth:	550 mm (21.7 in.)
Stack Mounting Flange:	DN80 PN10/16 or 3 in. 150 lb ANSI; minimum hole diameter 88 mm (3.5 in.)
Materials:	Enclosure: Powder-coated aluminum Probe: 316 stainless steel
Air Purge:	30 - 40 liter/minute (1.05 to 1.41 cfm)
Sealing:	IP66
Power Supply:	24 V DC provided by control unit
Compliance:	PS-11, 40 CFR 1040.10, 1040.11

Controller	Single	Multi
Sensor Channels:	1	Up to 16
Display:	Graphical Display	Graphical Display
4-20 mA Outputs:	1	4
Outputs:	1x RS485 Modbus	1x RS485 Modbus
Size (H x W x D):	8.7 in. x 4.8 in. x 3.2 in.	10.4 in. x 6.3 in. x 3.6 in.
Power:	100 - 240 V AC, 1 A	100 - 240 V AC, 1 A

SEE OUR OTHER DUST AND OPACITY RELATED LITERATURE:



MODEL 4500mkIII
COMPLIANCE DUST
AND OPACITY
MONITOR



MODEL 4400
OPACITY
MONITORING

DISCOVER HOW OUR BROAD RANGE
OF NON-CONTACT TEMPERATURE
MEASUREMENT AND COMBUSTION &
EMISSIONS PRODUCTS OFFER A
SOLUTION FOR YOUR PROCESS

WWW.AMETEK-LAND.COM



CONTACT US



www.ametek-land.com



land.enquiry@ametek.com



We are fully committed to Quality Assurance. See all our accreditations at AMETEK-LAND.COM/QUALITY