

SYSTEM 4 THERMOMETER

USER GUIDE

PUBLICATION N° 198.006

LANGUAGE: ENGLISH



System 4 Standard Bodied Thermometer



LAND[®]
AMETEK[®]



QUALITY CUSTOMER SOLUTIONS

Health and Safety Information



Read all of the instructions in this booklet - including all the **WARNINGS** and **CAUTIONS** - *before* using this product. If there is any instruction which you do not understand, **DO NOT USE THE PRODUCT**.

Safety Signs

WARNING
 Indicates a potentially hazardous situation which, if not avoided, could result in death or personal injury.

CAUTION
 Indicates a potentially hazardous situation which, if not avoided, could result in minor or moderate injury to the user or users, or result in damage to the product or to property.

NOTE
 Indicates a potentially hazardous situation which, if not avoided, could result in damage or loss of data.

Signs and Symbols used on equipment and Documentation



Caution, risk of electric shock.



Caution, attention to possibility of risk of damage to the product, process or surroundings. Refer to instruction manual.



Caution, hot surface.



Protective Conductor Terminal.



Observe precautions for handling electrostatic discharge sensitive devices.

Equipment Operation

Use of this instrument in a manner not specified by LAND may be hazardous. Read **and understand** the user documentation supplied **before** installing and operating the equipment.

The safety of any system incorporating this equipment is the responsibility of the assembler.

Protective Clothing, Face and Eye Protection

It is possible that this equipment is to be installed on, or near to, machinery or equipment operating at high temperatures and high pressures. Suitable protective clothing, along with face and eye protection must be worn. Refer to the health and safety guidelines for the machinery/equipment before installing this product. If in doubt, contact LAND.



Wear Protective Gloves



Wear Protective Clothing



Wear Eye Protection



Wear Ear Protection



Wear Safety Boots



Wear Face Protection

Electrical Power Supply

Before working on the electrical connections, all of the electrical power lines to the equipment must be isolated. All the electrical cables and signal cables must be connected exactly as indicated in these operating instructions. If in doubt, contact LAND.

Contact Us

UK - Dronfield

Land Instruments International
Tel: +44 (0) 1246 417691

China

AMETEK Land China Service
Tel: +86 21 5868 5111 ext 122

USA - Pittsburgh

AMETEK Land, Inc.
Tel: +1 412 826 4444

India

AMETEK Land India Service
Tel: +91 - 80 67823240

Email: land.enquiry@ametek.com

Web: www.ametek-land.com

For further details on all AMETEK Land offices, distributors and representatives, please visit our website.

Storage

The instrument should be stored in its packaging, in a dry sheltered area.

The maximum storage temperature is 10 °C (18 °F) higher than the maximum operating temperature.

The minimum storage temperature is 10 °C (18 °F) lower than the minimum operating temperature.

Refer to the Technical Specification for details of the operating temperature limits.

Unpacking

Check all packages for external signs of damage. Check the contents against the packing note.

Lifting Instructions

Where items are too heavy to be lifted manually, use suitably rated lifting equipment. Refer to the Technical Specification for weights. All lifting should be carried out in accordance with local and national regulations.

Return of Damaged Goods

IMPORTANT If any item has been damaged in transit, this should be reported to the carrier and to the supplier immediately. Damage caused in transit is the responsibility of the carrier not the supplier.

DO NOT RETURN a damaged instrument to the sender as the carrier will not then consider a claim. Save the packing with the damaged article for inspection by the carrier.

Return of Goods for Repair

If you need to return goods for repair please contact our Customer Service Department for details of the correct returns procedure.

Any item returned to LAND should be adequately packaged to prevent damage during transit.

You must include a written report of the problem together with your own name and contact information, address, telephone number, email address etc.

Design and Manufacturing Standards

The Quality Management System of Land Instruments International is approved to BS EN ISO 9001 for the design, manufacture and on-site servicing of combustion, environmental monitoring and non-contact temperature measuring instrumentation.

Registered ISO9001 Management System approvals apply in the USA.

UK Calibration Laboratory: UKAS 0034.

USA Calibration Laboratory: ANAB Accredited ISO/IEC 17025.

National Accreditation Board for Testing and Calibration Laboratories approvals apply in India.

Operation of radio transmitters, telephones or other electrical/electronic devices in close proximity to the equipment while the enclosure doors of the instrument or its peripherals are open, may cause interference and possible failure where the radiated emissions exceed the EMC directive.

The protection provided by this product may be invalidated if alterations or additions are made to the structural, electrical, mechanical, pneumatic, software or firmware components of this system. Such changes may also invalidate the standard terms of warranty.

Copyright

This manual is provided as an aid to owners of LAND's products and contains information proprietary to LAND. This manual may not, in whole or part, be copied, or reproduced without the expressed written consent of LAND.

Contents

1	Introduction	1-1
1.1	About this guide	1-1
1.2	About the thermometer	1-1
1.3	About System 4	1-1
1.4	Unpacking the thermometer	1-1
1.5	Nomenclature	1-3
2	Specifications	2-1
2.1	M1 Series Thermometers	2-1
2.2	M2+ Series Thermometers	2-2
2.3	M4 Series Thermometers	2-3
2.4	M6+ Series Thermometers	2-4
2.5	R1 Series Thermometers	2-5
3	Installing the Thermometer	3-1
3.1	Choosing a location for the thermometer	3-1
4	Using the Thermometer	4-1
4.1	Focusing the lens on the target	4-1
4.2	Electrical Connections	4-2
5	Using the Web Server (+ models only)	5-1
5.1	Network Adapter Settings	5-1
5.2	Using the web server	5-2
5.3	Updating the Firmware via the Web Server	5-2
6	Emissivity Tables	6-1
6.1	Alloys	6-1
6.2	Metals	6-2
6.3	Refractories	6-3
6.4	Plastics (M7 Thermometer only)	6-3
6.5	Miscellaneous	6-4
7	Maintenance	7-1
8	APPENDIX A - Discontinued Thermometers	8-1
8.1	M2 Series Thermometers	8-1
8.2	M5 Series Thermometers	8-2
8.3	M6 Series Thermometers	8-3
8.4	M6 Series Thermometers	8-4
8.5	M6 Series Thermometers	8-5

1

INTRODUCTION

1.1 About this guide

This guide gives the information necessary for you to operate an LAND System 4 Thermometer.

Basic information regarding installation is contained within the Installation Guide.

1.2 About the thermometer

The LAND System 4 thermometer is an accurate, focusable, non contact thermometer designed for use in conjunction with the System 4 Landmark processors.

The thermometer features include:

- Focusable optical system with through-the-lens sighting to give precise target definition.
- 4 to 20 mA output, linear over the temperature span of the thermometer.

1.3 About System 4

LAND System 4 is a range of high accuracy thermometers, state of the art processors and rugged mounting accessories designed to provide precise, non contact temperature measurement in a wide range of industrial applications.

An air purge, protection jacket and back cap are available for use with the thermometer in hostile locations.

1.4 Unpacking the thermometer

The package containing the thermometer will contain the following items:

- CD containing System 4 User Documentation.
- System 4 thermometer (fitted with protection caps on the lens and the eyepiece).
- Eye comfort filter. Fitted only to instruments where the temperature range exceeds 1600 °C/2900 °F.
- The thermometer will be supplied pre-fitted with either a Standard lens (denoted VG/VC) or a Short Focus lens (denoted SG/SF).

It is recommended that the front lens protection cap is kept attached until the thermometer is installed and that the eyepiece cap continues to be used after installation.



Fig. 1-1 LAND System 4 thermometer

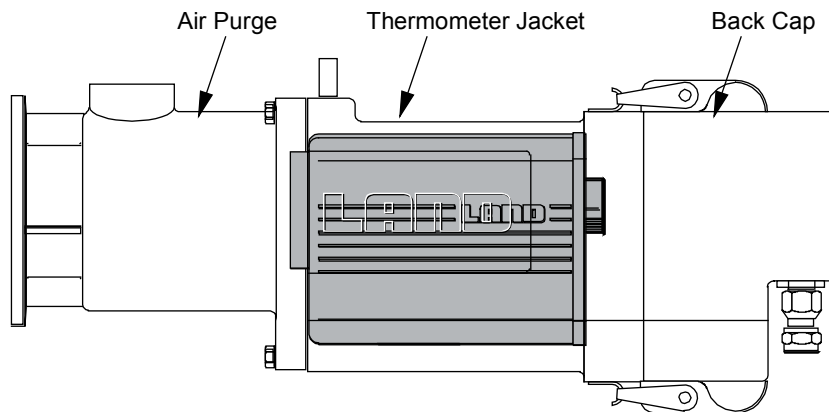

Fig. 1-2 System 4 Thermometer with Air Purge, Protection Jacket and Back Cap

1.5 Nomenclature

The thermometer detail label is on the rear face of the thermometer above the eyepiece. The thermometer instrument type nomenclature is explained in Fig. 1-3.

Make a note of your thermometers instrument type and Serial Number in the space provided below. This information is required to configure a Landmark processor to work with your thermometer.

Instrument type: / /

Serial Number: / /

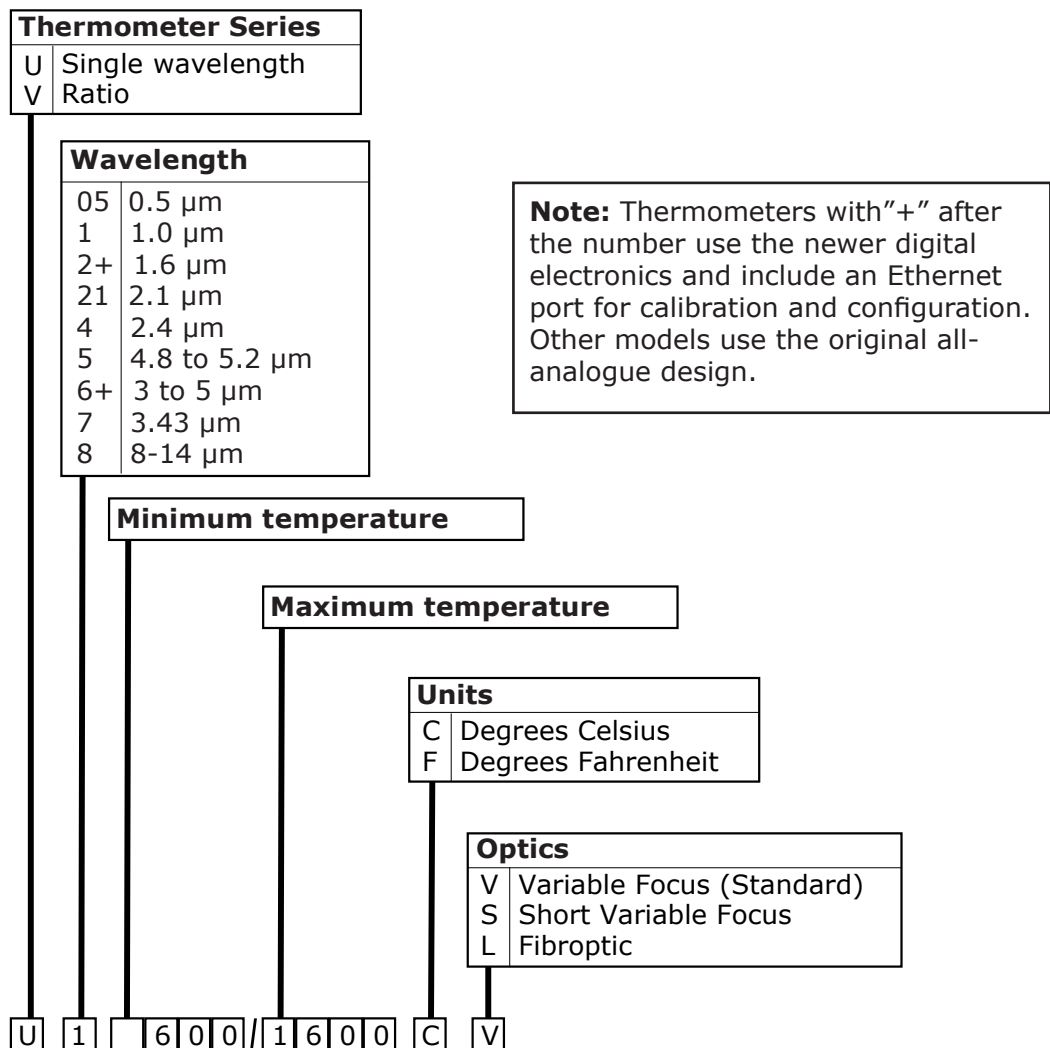

Fig. 1-3 System 4 Thermometer Nomenclature

2

SPECIFICATIONS

2.1 M1 Series Thermometers

Thermometer Model	M1 450/1000C	M1 850/1850F	M1 600/1600C	M1 1100/2900F	M1 800/2600C	M1 1500/4700F
Temperature Range:	450 to 1000 °C	850 to 1850 °F	600 to 1600 °C	1100 to 2900 °F	800 to 2600 °C	1500 to 4700 °F
Wavelength:	1 μm					
Response Time:	5 ms (0 to 95 %)					
Sighting:	6° through the lens					
Target Size:	>98% of energy within graticule					
Magnification:	1.8x					
Eye Relief:	30mm (1.2in)					
Field of View (Nominal):	30:1		100:1		200:1	
Focus Range						
Standard:	0.5m (19.7in) to infinity					
Short Variable Focus:	0.35m to 1.0m (13.6in to 39.3in)					
Min. Target Diameter:	11.7mm (0.46in)		3.5mm (0.13in)		1.8mm (0.07in)	
Accuracy**						
Repeatability:	≤1K			≤2K		
Absolute:	0.4%K			0.7%K		
Stability (Temperature):	0.2°/°ambient			0.3°/°ambient		
Stability (Time):	2 °C (4 °F) per year					
Vibration:	3G any axis 10 to 300Hz					
Humidity:	0 to 99% non condensing					
Sealing:	To IP65 / NEMA 4X requirements					
Ambient Temperature						
Specified:	0 to 70 °C (32 to 158 °F)					
Operating:	-10 to 80 °C (14 to 176 °F)					
CE	EN 50-082-2 (immunity) EN 50-081-1 (emission) IEC 1010 (safety)					

** Accuracy specifications above apply when the System 4 is used with a Landmark Technic or Landmark Graphic processor. Measurement uncertainties are increased by 50% when used with the Landmark Basic processor.

2.2 M2+ Series Thermometers

Thermometer Model	M2+ 300/1100C	M2+ 600/2000F
Temperature Range:	300 to 1100 °C	600 to 2000 °F
Wavelength:	1.6 μm	
Response Time:	5 ms (0 to 95%)	
Sighting:	6° through the lens	
Target Size:	>98% of energy within graticule	
Magnification:	1.8x	
Eye Relief:	30 mm (1.2 in)	
Field of View (Nominal):	100:1	
Focus Range		
Standard:	0.5 m (19.7 in) to infinity	
Short Variable Focus:	0.35 m to 1.0 m (13.6 in to 39.3 in)	
Min. Target Diameter:	3.5 mm (0.13 in)	
Accuracy**		
Repeatability:	≤1 K	
Absolute:	0.25%K + 1 K	
Stability (Temperature):	0.2°/°ambient	
Stability (Time):	2 °C (4 °F) per year	
Vibration:	3G any axis 10 to 300Hz	
Humidity:	0 to 99% non condensing	
Sealing:	To IP65 / NEMA 4X requirements	
Ambient Temperature		
Specified:	0 to 60 °C (32 to 140 °F)	
Operating:	-10 to 60 °C (14 to 140 °F)	
CE	EN 50-082-2 (immunity) EN 50-081-1 (emission) IEC 1010 (safety)	

** Accuracy specifications above apply when the System 4 is used with a Landmark Technic or Landmark Graphic processor. Measurement uncertainties are increased by 50% when used with the Landmark Basic processor.

2.3 M4 Series Thermometers

Thermometer Model	M4 50/250C	M4 150/500F	M4 150/550C	M4 300/1000F
Temperature Range:	50 to 250 °C	150 to 500 °F	150 to 550 °C	300 to 1000 °F
Wavelength:	2.4 μm			
Response Time:	100ms (0 to 95%)			
Sighting:	6° through the lens			
Target Size:	>98% of energy within graticule			
Magnification:	1.8x			
Eye Relief:	30mm (1.2in)			
Field of View (Nominal):	30:1		100:1	
Focus Range				
Standard:	0.5m (19.7in) to infinity			
Short Variable Focus:	0.35m to 1.0m (13.6in to 39.3in)			
Min. Target Diameter:	11.7mm (0.46in)		3.5mm (0.13in)	
Accuracy**				
Repeatability:	≤1K		≤1K	
Absolute:	3K		4K	
Stability (Temperature):	0.1°/°ambient			
Stability (Time):	1°C (2°F) per year			
Vibration:	3G any axis 10 to 300Hz			
Humidity:	0 to 99% non condensing			
Sealing:	IP65			
Ambient Temperature				
Specified:	5 to 45°C (41 to 113°F)			
Operating:	0 to 50°C (32 to 122°F)			
CE	EN 50-082-2 (immunity) EN 50-081-1 (emission) IEC 1010 (safety)			

** Accuracy specifications above apply when the System 4 is used with a Landmark Technic or Landmark Graphic processor. Measurement uncertainties are increased by 50% when used with the Landmark Basic processor.

2.4 M6+ Series Thermometers

Thermometer Model	M6+ 0/300C	M6+ 50/600F	M6+ 100/700C	M6+ 200/1300F
Temperature Range:	0 to 300 °C	50 to 600 °F	100 to 700 °C	200 to 1300 °F
Wavelength:	3 to 5 μm (nominal)			
Response Time:	<100 ms (0 to 95%)			
Sighting:	6° through the lens			
Target Size:	>98% of energy within graticule			
Magnification:	1.8x			
Eye Relief:	30 mm (1.2 in)			
Field of View (Nominal):	75:1		100:1	
Focus Range				
Standard:	0.5 m (19.7 in) to infinity			
Short Variable Focus:	0.35 m to 1.0 m (13.6 in to 39.3 in)			
Min. Target Diameter				
Standard:	6.7 mm / 0.26 in		5.0 mm / 0.20 in	
Short Variable Focus:	4.7 mm / 0.19 in		3.5 mm / 0.13 in	
Accuracy**				
Repeatability:	<1 K		<1 K	
Absolute:	0.3%K + 2.5K		0.3%K + 2K	
Stability (Temperature):	0.15K/K ambient*		0.2K/K ambient	
Vibration:	3g any axis 10 to 300Hz			
Humidity:	0 to 99% non condensing			
Sealing:	IP65			
Ambient Temperature				
Specified:	5 to 50 °C (41 to 122 °F)			
Operating:	0 to 60 °C (32 to 140 °F)			
CE	EN 50-082-2 (immunity) EN 50-081-1 (emission) IEC 1010 (safety)			

* 0.2 K/K for target temperature < 30 °C / 86 °F

** Accuracy specifications above apply when the System 4 is used with a Landmark Technic or Landmark Graphic processor. Measurement uncertainties are increased by 50% when used with the Landmark Basic processor.

2.5 R1 Series Thermometers

Thermometer Model	R1 600/1600C	R1 1100/2900F	R1 1000/2600C	R1 1800/4700F
Temperature Range:	600 to 1600 °C	1100 to 2900 °F	1000 to 2600 °C	1800 to 4700 °F
Wavelength:	0.85 to 1.1 μm			
Response Time:	15 ms (0 to 95%)			
Sighting:	6° through the lens			
Target Size:	>98% of energy within graticule			
Magnification:	1.8x			
Eye Relief:	30 mm (1.2 in)			
Field of View (Nominal):	50:1		200:1	
Focus Range				
Standard:	0.5 m (19.7 in) to infinity			
Short Variable Focus:	0.35 m to 1.0 m (13.6 in to 39.3 in)			
Min. Target Diameter:	7 mm (0.27 in)		1.8 mm (0.07 in)	
Accuracy**				
Repeatability:	≤1K		≤2K	
Absolute:	≤0.65%K		≤1.1%K	
Stability (Temperature):	0.05 %/° ambient		0.1 %/° ambient	
Stability (Time):	2 °C (4 °F) per year			
Vibration:	3G any axis 10 to 300Hz			
Humidity:	0 to 99% non condensing			
Sealing:	IP65			
Ambient Temperature				
Specified:	0 to 50 °C (32 to 122 °F)			
Operating:	-10 to 60 °C (14 to 140 °F)			
CE	EN 50-082-2 (immunity) EN 50-081-1 (emission) IEC 1010 (safety)			

** Accuracy specifications above apply when the System 4 is used with a Landmark Technic or Landmark Graphic processor. Measurement uncertainties are increased by 50% when used with the Landmark Basic processor.

3

INSTALLING THE THERMOMETER

This section contains similar information to the thermometer Installation Guide.

If the thermometer is to be used in conjunction with a protection jacket and air purge, refer to the installation guides provided with those accessories.

If the thermometer is to be installed in a location where the ambient temperature is within the ranges specified for the thermometer, and no air purging is required to keep the lens clean, the thermometer can be mounted using the two tapped holes on the mounting pad. Either hole can be used for direct tripod mounting.

A swivel ball mounting (S4 - B) is available from LAND. This mounting accessory enables you to easily adjust the thermometer's line of sight.

3.1 Choosing a location for the thermometer

If your thermometer is an 'M' series thermometer (e.g. M1 600 / 1600 C), it must be positioned such that, at the chosen target distance, the target is large enough to completely fill the area covered by the graticule of the eyepiece (Refer to Section 3.1.1). The thermometer's view of the target area must not be obstructed.

If your thermometer is an 'R' series thermometer (e.g. R1 1000 / 2600 C), it is not essential for the target to completely fill the area covered by the graticule. The overall dimensions of the thermometer installation are given in Fig. 3-1.

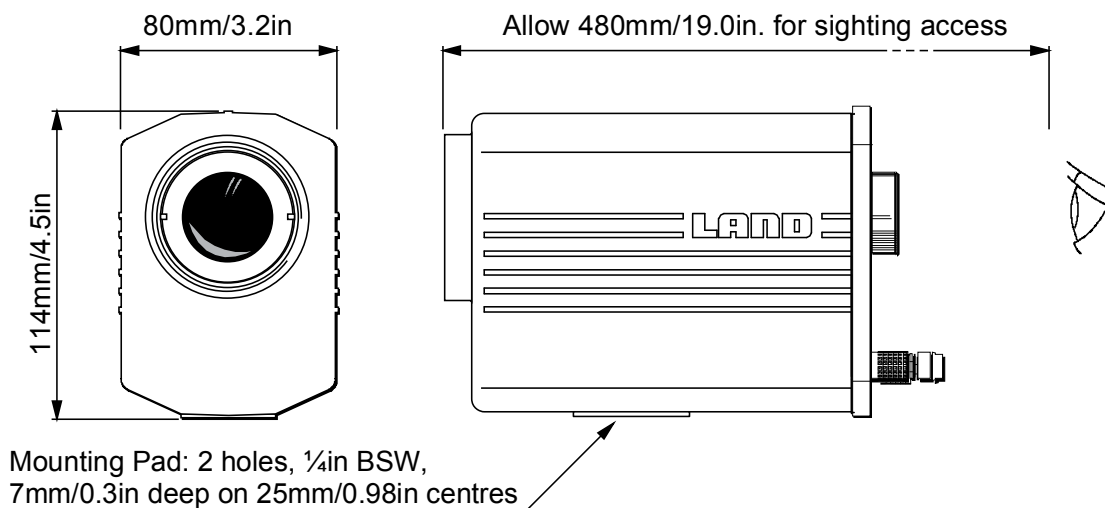

Fig. 3-1 Thermometer installation dimensions

3.1.1 Target size calculation

There are two types of lens available for use with the System 4 thermometer.

Standard lens: Focusable from 500 mm to infinity denoted [VG/VC]

Short focus lens: Focusable from 350 mm to 1000 mm denoted [SG/SF]

For both lenses, the target area is defined as the area covered by the graticule.

To calculate the minimum target size at any distance, refer to Fig. 3-2.

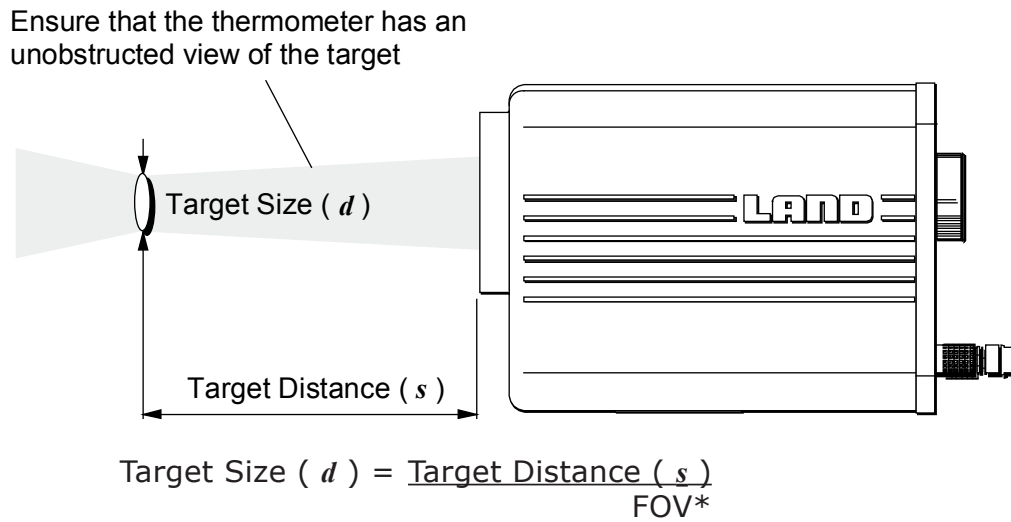

* FOV - Refer to your thermometer's specification for this value.
i.e. If the Field of view is 100:1, use '100' for the FOV value.

Fig. 3-2 Target size calculation

4

USING THE THERMOMETER

Once the thermometer has been installed in its chosen location, the lens must be focused on the target area.



CAUTION

If the object to be measured is suspected of being at a temperature higher than 1600°C, make sure that the eye comfort filter is fitted before proceeding with installation.

4.1 Focusing the lens on the target

To focus on the target.

- 1) Remove the lens protection cap from the thermometer.
- 2) Remove the eyepiece protection cap on the rear face of the thermometer to reveal the Focus ring (See Fig. 4-1).

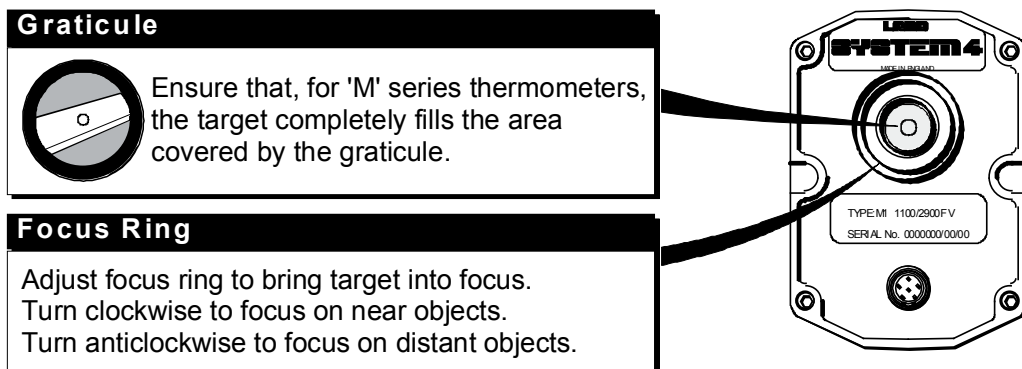

Fig. 4-1 Location of Focus Ring and Graticule on rear face of thermometer

- 3) Look through the eyepiece. If you wear spectacles, you do not need to remove them, as the graticule image is positioned for viewing either with or without corrected vision.

The target area is defined as the area within the graticule.

NOTE

The image in the viewfinder appears upside down.

- 4) If the required target is not within the graticule, adjust the thermometer mounting until the target fills the graticule.

NOTE

A range of thermometer mounting accessories, to suit all measurement locations, is available from LAND.

- 5) Turn the focus ring to bring the target into focus.
To move the focus nearer to the thermometer turn the ring clockwise.
To move the focus away from the thermometer turn the ring anticlockwise.
- 6) To check that the target is in focus, use the 'parallax' method. i.e. look through the eyepiece and make small side-to-side movements of your head. The target is in best focus when there is no apparent movement of the image with respect to the graticule.
- 7) Make any necessary adjustments to the thermometer's mounting to ensure that it is viewing the required target.
- 8) When the target is in focus and, for 'M' series thermometers, the target fills the graticule, replace the eyepiece protection cap and ensure that the thermometer is mounted securely.

4.2 Electrical Connections

The electrical connections for the thermometer's power supply, emissivity input and temperature output are made via the 6-way socket on the rear of the thermometer. See Fig. 4-2.

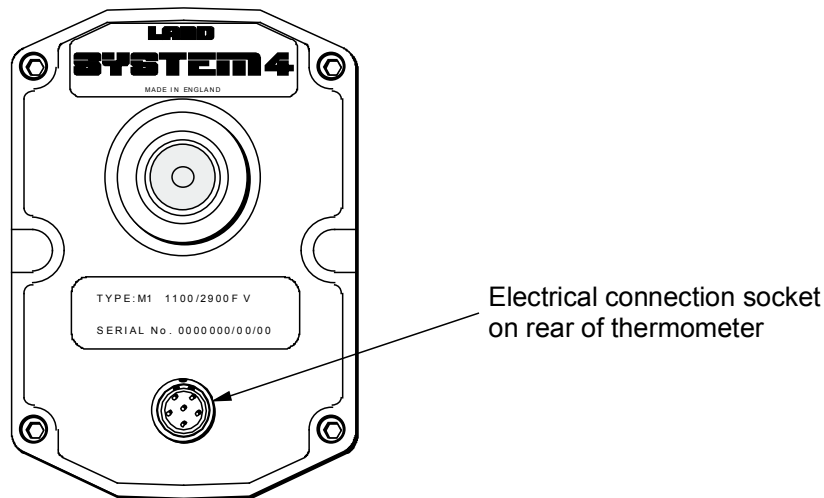

Fig. 4-2 Location of 6-way electrical connection socket

Electrical connection to the thermometer must be made by either the pre-wired plug (LAND Part N^o 029.673) or via the plug housed in the Back Cap (LAND Part N^o 091.562).

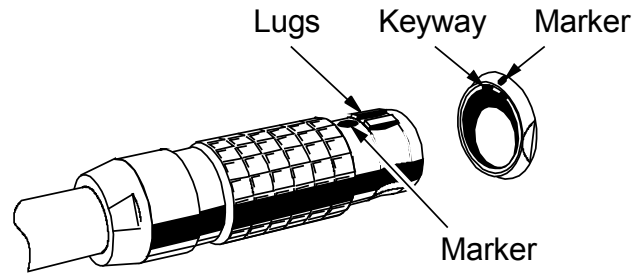

Fig. 4-3 Connection of the pre-wired cable to the thermometer

To connect the cable;

- 1) Refer to Fig. 4-3. Align the red marker near the lugs of the pre-wired plug with the red marker above the keyway in the socket on the thermometer.
- 2) Push the plug into the socket.

To disconnect the cable;

- 1) Grip the locking sleeve section of the plug.
- 2) Pull the plug outwards to release the locking mechanism and disconnect the cable.

4.2.1 Electrical connection to Landmark processors

The electrical connections required by the System 4 Thermometer are as follows:

- 1) 30V between V+ and V-.
- 2) 4 to 20mA input on E+ and E- to represent emissivity of 0.2 to 1.0.
- 3) 4 to 20mA output on T+ and T- giving temperature linearly across the thermometer range.

NOTE

In typical applications, Ratio thermometers require a minimum warm-up time of 2 to 3 minutes after switching on before their accuracy stabilises. However, in the case of R1 Ratio thermometers, this warm-up time can be 20 to 30 minutes.

When the thermometer is used in conjunction with a System 4 Landmark Processor, the thermometer derives its power supply, emissivity input and temperature output from the processor. To connect the thermometer to the processor, use the 6-way cable from the thermometer to wire up the 7-way cable connector supplied with the processor (Refer to the Processor Installation Guide). The cable connection schedule is given in Fig. 4-4.

Cable Colour	Label	Function
Yellow	T	4 to 20mA linear temperature signal drive
Blue	T-	4 to 20mA linear temperature signal return
White	E+	4 to 20mA emissivity signal drive
Screen	Screen	Screen
Red	V	24 to 30V d.c. power (positive)
Black	V-	24 to 30V d.c. power (negative)
Green	E-	4 to 20mA emissivity signal return

There are two variants of plug: Type A or Type B

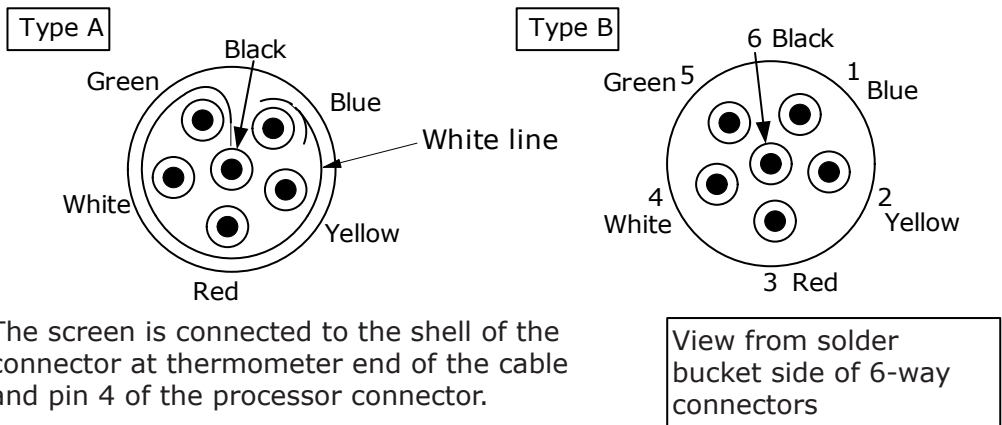

Fig. 4-4 Cable connection schedule

5

USING THE WEB SERVER (+ MODELS ONLY)

System 4 M2+ and M6+ have a web server which can be used to update its firmware and change certain settings. You can access the Web Server via a computer/device with an Ethernet port and a web browser. The following browsers are supported:

- Google Chrome
- Microsoft Edge
- Mozilla Firefox

5.1 Network Adapter Settings

To communicate with the System 4, you need to specify the correct Network Adapter Settings on your computer/device. The instructions below apply to Windows 10 systems. If you have a different operating system, refer to the user guide/help files for your system.

1. In your computer's Type here to search box (bottom left of screen), type Network Connections. The Network Connections window displays details of each network to which your computer is connected.
2. Right-click on the Network containing your System 4 and select the Properties option.
3. Select the Internet Protocol option and click on Properties.
4. Select the use the following IP address option and enter the values:
IP address: 10.1.10.150**
Subnet mask: 255.255.0.0
** the default IP address for the System 4 is 10.1.10.50. For your computer, you can select any IP address from 10.1.10.1 to 10.1.10.255 apart from 10.1.10.50.
5. Click on OK to save these settings.
6. Connect the computer to the pyrometer using an M12 to RJ45 4-pin D-coded Ethernet cable. LAND part number 816830 is recommended.
- 7) Open a web browser.
- 8) Type 10.1.10.50 in the browser's address bar. You will see the System 4 web server interface.

5.2 Using the web server

The web server screen is shown in Fig 5-1. It allows you to change between Celsius and Fahrenheit outputs, and to update the System 4 firmware. The default password is the first six digits of your instrument serial number. For example, if your serial number is 876543 21, the password is 876543.

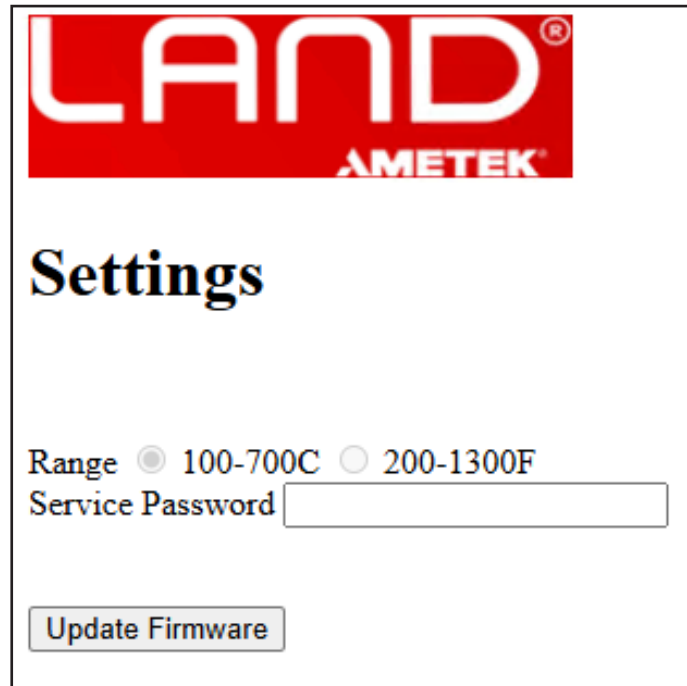
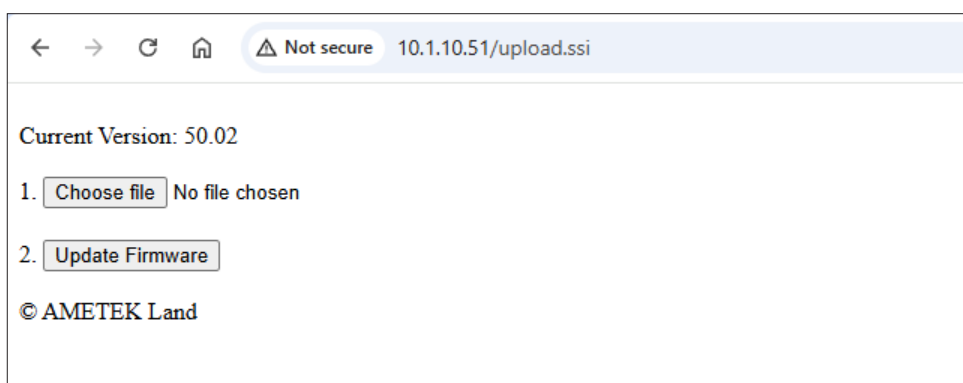

Fig. 5-1 Web server screen

5.3 Updating the Firmware via the Web Server

1. Download the latest System 4+ firmware from the following web address: <https://www.ametek-land.com/products/software>
2. Connect a PC to the instrument and open the web server by entering the device IP address into a web browser. This will show the main menu (see Fig. 5-1).
3. Enter the instrument password and click the Update Firmware button.



4. Click the Choose File button. Navigate to the downloaded firmware file and select it.

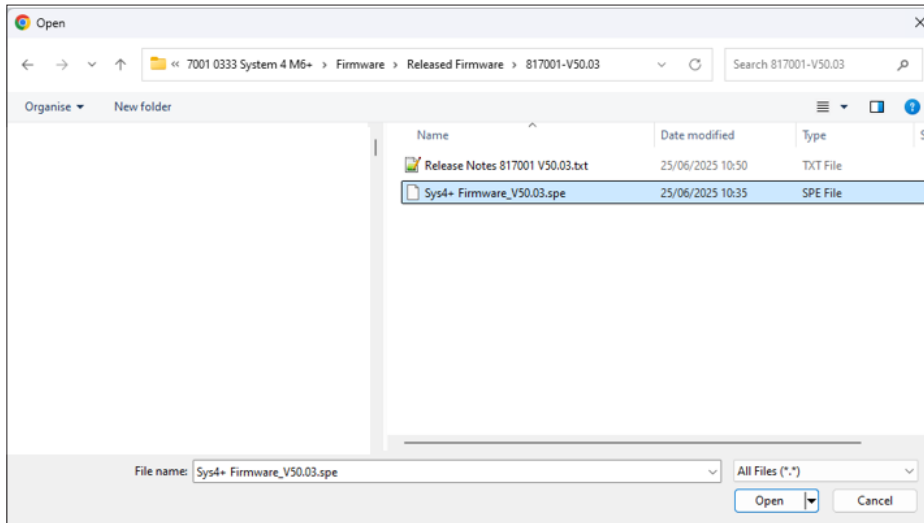

5. Click Update Firmware.
The Loading bar will show progress of the update.

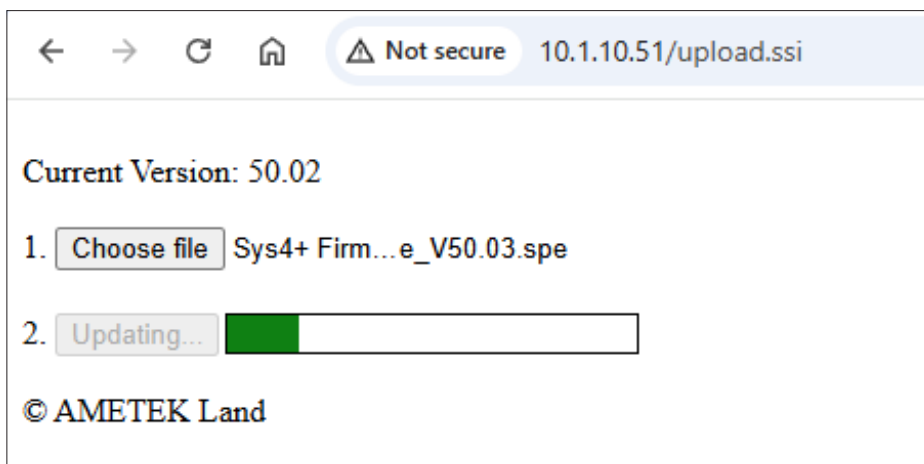

When the update is complete, the device will reset, and the web browser will navigate back to the main Web Server screen

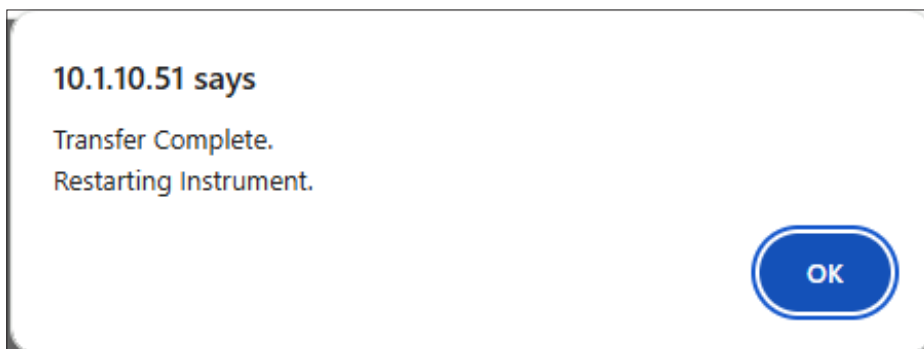

6

EMISSIVITY TABLES

In order to obtain accurate temperature measurements, the emissivity value of the target surface must be known.

This section of the Thermometer User Guide contains emissivity values of the most commonly measured materials for each System 4 thermometer. Where no emissivity value is quoted, this means that either the thermometer is not suitable for the measurement application or the temperature of the target is outside the thermometer's measurement span. If you have a query regarding the emissivity of the target in your measurement application, contact LAND.

6.1 Alloys

Alloys					
Material	System 4 Thermometer Series				
	M1	M2+	M4	M6+	M8
Brass	0.20	0.18	-	0.10	0.03
<i>oxidised</i>	0.70	0.70	0.70	0.61	0.60
Chromel & Alumel	0.30	0.30	0.30	-	0.30
<i>oxidised</i>	0.80	0.80	0.80	-	0.80
Constantin & Manganin	0.25	0.22	0.20	-	0.05
<i>oxidised</i>	0.65	0.60	0.60	-	0.35
Inconel	0.30	0.30	0.30	0.28	0.10
<i>oxidised</i>	0.85	0.85	0.85	0.85	0.85
Monel	0.25	0.22	0.20	0.10	0.10
<i>oxidised</i>	0.70	0.70	0.70	0.45	0.70
Nichrome	0.30	0.22	-	-	0.20
<i>oxidised</i>	0.85	0.85	0.85	0.90	0.85

6.3 Refractories

6.2 Metals

Metals					
Material	System 4 Thermometer Series				
	M1	M2+	M4	M6+	M8
Aluminium	0.13	0.09	0.08	0.05	0.03
<i>oxidised</i>	0.40	0.40	0.40	0.30	0.35
Chromium	0.43	0.34	-	0.15	0.07
<i>oxidised</i>	0.75	0.80	-	-	0.85
Cobalt	0.32	0.28	-	0.18	0.04
<i>oxidised</i>	0.70	0.65	-	-	0.35
Copper	0.06	0.05	0.04	0.04	0.03
<i>oxidised</i>	0.85	0.85	0.85	0.85	0.80
Gold	0.05	0.02	0.02	0.02	0.02
Iron & Steel	0.35	0.30	-	0.18	0.10
<i>oxidised</i>	0.85	0.85	0.85	0.85	0.80
Lead	0.35	0.28	-	0.16	0.13
<i>oxidised</i>	0.65	0.65	0.65	0.63	0.65
Magnesium	0.27	0.24	0.20	0.12	0.07
<i>oxidised</i>	0.75	0.75	0.75	-	0.75
Molybdenum	0.33	0.25	-	0.07	0.10
<i>oxidised</i>	0.80	0.80	0.80	0.80	0.80
Nickel	0.35	0.25	-	0.15	0.04
<i>oxidised</i>	0.85	0.85	-	-	0.85
Palladium	0.28	0.23	-	0.08	0.05
Platinum	0.27	0.22	0.18	0.10	0.07
Rhodium	0.25	0.18	-	0.07	0.05
Silver	0.05	0.04	0.04	0.03	0.02
<i>oxidised</i>	0.10	0.10	0.10	-	0.12
Tin	0.40	0.28	0.12	0.09	0.06
<i>oxidised</i>	0.60	0.60	0.60	-	0.60
Titanium	0.55	0.50	0.42	0.30	0.15
<i>oxidised</i>	0.80	0.80	-	-	0.60
Tungsten	0.39	0.30	0.20	0.13	0.06
Zinc	0.50	0.32	0.10	0.05	0.04
<i>oxidised</i>	0.60	0.55	-	0.11	0.30

Refractories						
Material	System 4 Thermometer Series					
	M1	M2+	M4	M6+	M8	
Alumina	0.30	0.30	0.30	0.40	0.60	
Brick	red	0.80	0.80	0.80	0.93	0.90
	white refractory	0.30	0.35	-	-	0.80
	silica	0.55	0.60	-	-	0.80
	sillimanite	0.60	0.60	-	-	0.60
Ceramics	0.40	0.50	-	-	0.90	
Magnesite	-	-	0.60	-	-	

6.4 Plastics (M7 Thermometer only)

Plastics										
Material	Thickness (µm)									
	5	10	20	40	60	80	100	150	200	300
Acrylic	0.18	0.35	0.59	0.82	0.91	0.94	0.95	0.96	0.96	0.96
Cellulose Acetate	0.11	0.24	0.44	0.69	0.82	0.88	0.92	0.95	0.96	0.96
Polyester (PET)	0.03	0.09	0.21	0.39	0.53	0.64	0.72	0.83	0.90	0.94
Polyamide (Nylon)	0.35	0.59	0.82	0.94	0.96	0.96	0.96	0.96	0.96	0.96
Polycarbonate	0.07	0.18	0.34	0.58	0.73	0.82	0.87	0.93	0.95	0.96
Polyethylene	0.58	0.82	0.94	0.96	0.96	0.96	0.96	0.96	0.96	0.96
Polypropylene	0.61	0.84	0.95	0.96	0.96	0.96	0.96	0.96	0.96	0.96
Polystyrene	0.18	0.35	0.59	0.82	0.91	0.94	0.95	0.96	0.96	0.96
Polyurethane	0.14	0.29	0.51	0.76	0.87	0.92	0.94	0.96	0.96	0.96
Polyvinyl Chloride (PVC)	0.16	0.33	0.56	0.80	0.90	0.93	0.94	0.96	0.96	0.96
Polyvinylidene Chloride (PVDC)	0.02	0.08	0.18	0.35	0.49	0.59	0.67	0.81	0.88	0.94

6.5 Miscellaneous

Miscellaneous Materials						
Material		System 4 Thermometer Series				
		M1	M2+	M4	M6+	M8
Asbestos (board/paper/cloth)		0.90	0.90	-	0.90	0.90
Asphalt		0.85	0.85	-	0.90	0.85
Carbon	<i>graphite</i>	0.85	0.85	-	0.85	0.80
	<i>soot</i>	0.95	0.95	-	0.95	0.95
Cement & Concrete		0.65	0.70	-	0.90	0.90
Cloth - all types, close weave (Open weave reduces emissivity)		0.75	0.80	0.85	0.85	-
Glass	<i>3mm thick</i>	-	-	-	>0.90	-
	<i>6mm thick</i>	-	-	-	>0.90	-
	<i>12mm thick</i>	-	-	-	>0.90	-
	<i>20mm thick</i>	0.80	-	-	>0.90	-

7

MAINTENANCE

Thermometer maintenance consists mainly of ensuring that the lens is clean. If the lens becomes dirty, clean it with lens cleaning fluid and a soft cloth.

If it is found that the lens is repeatedly becoming dirty, it may be necessary to use the thermometer in conjunction with the System 4 air purge (LAND Part N^o 091.561). Contact LAND for more information.

If the thermometer is used in conjunction with a cooling jacket, ensure that there is an adequate supply of cooling water.

Warning

Never 'over-cool' the thermometer, as this may result in condensation either on or inside the thermometer.

The flow rate required for cooling water is 1 litre per minute (0.035 cu. ft per minute).

If the thermometer is used in conjunction with an air purge, check that there is an adequate supply of clean air.

The flow rate required for purge air is 1 litre per second (2 cu. ft per minute).

8

APPENDIX A DISCONTINUED THERMOMETERS

8.1 M2 Series Thermometers

Thermometer Model	M2 300/1100C	M2 600/2000F
Temperature Range:	300 to 1100°C	600 to 2000°F
Wavelength:	1.6µm	
Response Time:	5 ms (0 to 95%)	
Sighting:	6° through the lens	
Target Size:	>98% of energy within graticule	
Magnification:	1.8x	
Eye Relief:	30mm (1.2in)	
Field of View (Nominal):	100:1	
Focus Range		
Standard:	0.5m (19.7in) to infinity	
Short Variable Focus:	0.35m to 1.0m (13.6in to 39.3in)	
Min. Target Diameter:	3.5mm (0.13in)	
Accuracy		
Repeatability:	≤1K	
Absolute:	0.25%K + 1K	
Stability (Temperature):	0.2°/°ambient	
Stability (Time):	2°C (4°F) per year	
Vibration:	3G any axis 10 to 300Hz	
Humidity:	0 to 99% non condensing	
Sealing:	To IP65 / NEMA 4X requirements	
Ambient Temperature		
Specified:	0 to 50°C (32 to 122°F)	
Operating:	-10 to 60°C (14 to 140°F)	
CE	EN 50-082-2 (immunity) EN 50-081-1 (emission) IEC 1010 (safety)	

8.2 M5 Series Thermometers

Thermometer Model	M5 400/1300C	M5 750/2400F	M5 1000/2500C	M5 1800/4500F
Temperature Range:	400 to 1300°C	750 to 2400°F	1000 to 2500°C	1800 to 4500°F
Wavelength:	4.8 to 5.2µm			
Response Time:	100ms (0 to 95%)			
Sighting:	6° through the lens			
Target Size:	>98% of energy within graticule			
Magnification:	1.8x			
Eye Relief:	30mm (1.2in)			
Field of View (Nominal):	100:1			
Focus Range				
Standard:	0.5m (19.7in) to infinity			
Short Variable Focus:	0.35m to 1.0m (13.6in to 39.3in)			
Min. Target Diameter:	3.5mm (0.13in)			
Accuracy				
Repeatability:	1K		1K	
Absolute:	0.6%K		0.5%K	
Stability (Temperature):	0.02%°T(K)/°C ambient			
Stability (Time):	2°C (4°F) per year			
Vibration:	3G any axis 10 to 300Hz			
Humidity:	0 to 99% non condensing			
Sealing:	IP65			
Ambient Temperature				
Specified:	0 to 70°C (32 to 158°F)			
Operating:	-10 to 80°C (14 to 176°F)			
CE	EN 50-082-2 (immunity) EN 50-081-1 (emission) IEC 1010 (safety)			

8.3 M6 Series Thermometers

Thermometer Model	M6 0/300C	M6 50/600F	M6 100/700C	M6 200/1300F
Temperature Range:	0 to 300 °C	50 to 600 °F	100 to 700 °C	200 to 1300 °F
Wavelength:	3 to 5 μm (nominal)			
Response Time:	<100 ms (0 to 95%)			
Sighting:	6° through the lens			
Target Size:	>98% of energy within graticule			
Magnification:	1.8x			
Eye Relief:	30 mm (1.2 in)			
Field of View (Nominal):	30:1		100:1	
Focus Range				
Standard:	0.5 m (19.7 in) to infinity			
Short Variable Focus:	0.35 m to 1.0 m (13.6 in to 39.3 in)			
Min. Target Diameter:	11.7 mm (0.46 in)		3.5 mm (0.13 in)	
Accuracy				
Repeatability:	<1 K		<1 K	
Absolute:	0.3% K + 1.5 K		0.3% K + 2 K	
Stability (Temperature):	0.15 °/° ambient		0.2 °/° ambient	
Stability (Time):	2 °C (4 °F) per year			
Vibration:	3 G any axis 10 to 300 Hz			
Humidity:	0 to 99% non condensing			
Sealing:	IP65			
Ambient Temperature				
Specified:	5 to 45 °C (41 to 113 °F)			
Operating:	0 to 50 °C (32 to 122 °F)			
CE	EN 50-082-2 (immunity) EN 50-081-1 (emission) IEC 1010 (safety)			

8.4 M7 Series Thermometers

Thermometer Model	M7 25/375C	M2 75/700F
Temperature Range:	25 to 375°C	75 to 700°F
Wavelength:	3.43 μm (nominal)	
Response Time:	<100 ms (0 to 95%)	
Sighting:	6° through the lens	
Target Size:	>98% of energy within graticule	
Magnification:	1.8x	
Eye Relief:	30 mm (1.2 in)	
Field of View (Nominal):	30:1	
Focus Range		
Standard:	0.5 m (19.7 in) to infinity	
Short Variable Focus:	0.35 m to 1.0 m (13.6 in to 39.3 in)	
Min. Target Diameter:	11.7 mm (0.46 in)	
Specified accuracy above the measurement range 75°C (167°F)		
Repeatability:	1.5°K	
Absolute:	3K	
Stability (Temperature):	0.1°/°ambient	
Stability (Time):	2°C (4°F) per year	
Vibration:	3G any axis 10 to 300 Hz	
Humidity:	0 to 99% non condensing	
Sealing:	IP65	
Ambient Temperature		
Specified:	5 to 45°C (41 to 113°F)	
Operating:	0 to 50°C (32 to 122°F)	
CE	EN 50-082-2 (immunity) EN 50-081-1 (emission) IEC 1010 (safety)	

8.5 M8 Series Thermometers

Thermometer Model	M8 0/1000C	M8 30/1830F
Temperature Range:	0 to 1000°C	30 to 1830°F
Wavelength:	8 to 14 μm (nominal)	
Response Time:	100ms (0 to 95%)	
Sighting:	6° through the lens	
Target Size:	>98% of energy within graticule	
Magnification:	1.8x	
Eye Relief:	30mm (1.2in)	
Field of View (Nominal):	100:1	
Focus Range		
Standard:	0.5m (19.7in) to infinity	
Min. Target Diameter:	5mm (0.2in)	
Accuracy		
Repeatability:	≤1K	
Absolute:	1%K +1K	
Interchangeability:	2K	
Stability (Temperature):	0.3°/°ambient	
Stability (Time):	2°C (4°F) per year	
Vibration:	3G any axis 10 to 300Hz	
Humidity:	0 to 99% non condensing	
Sealing:	To IP65 / NEMA 4X requirements	
Ambient Temperature		
Specified:	0 to 45°C (32 to 113°F)	
Operating:	0 to 70°C (32 to 158°F)	
CE	EN 50-082-2 (immunity) EN 50-081-1 (emission) IEC 1010 (safety)	

SYSTEM 4

FIXED SPOT NON-CONTACT THERMOMETERS



Land Instruments International
Dronfield, S18 1DJ,
England
Tel: +44 (0) 1246 417691
Email: land.enquiry@ametek.com
www.ametek-land.com

AMETEK Land - Americas
150 Freeport Road, Pittsburgh,
PA 15238, U.S.A.
Tel: +1 (412) 826 4444
Email: irsales@ametek.com
www.ametek-land.com

AMETEK Land China Service
Part A1 & A4, 2nd Floor #1
No. 26 Fute 3rd Road East,
Pilot Free Trade Zone 200131
Shanghai, China
Tel: +86 21 5868 5111 ext 122
Email: land.enquiry@ametek.com
www.ametek-land.com

AMETEK Land India Service
Divyasree N R Enclave, Block A,
4th Floor, Site No 1, EPIP Industrial Area
Whitefield, Bangalore- 560066 Karnataka,
India
Tel: +91 - 80 67823240
Email: land.enquiry@ametek.com
www.ametek-land.com

For a full list of international offices, please visit our website www.ametek-land.com

Copyright © 2026 LAND Instruments International.

Continuous product development may make it necessary to change these details without notice.

System 4 Thermometer User Guide, Issue 18, 08 December 2025