

# LANDCAL R1200P

## USER GUIDE

ISSUE 8: MARCH 2024  
PUBLICATION Nº 198.034  
LANGUAGE: ENGLISH



 CALIBRATION SOURCE



**LAND**  
**AMETEK®**



QUALITY CUSTOMER SOLUTIONS



## SAFETY WARNING

### **Insulation made from High Temperature Insulation Wool Refractory Ceramic Fibre, (better described as Alumino Silicate Wool) (ASW)**

This product contains alumino silicate wool products in its thermal insulation. These materials may be in the form of blanket or felt, formed board or shapes, mineral wool slab or loose fill wool. Whilst there is no evidence of any long term health hazards, we strongly recommend that safety precautions are taken whenever the materials are handled.

**Exposure to fibrous dust may cause respiratory disease.**

**When handling the material always use an approved respiratory protection equipment (RPE-i.e. FFP3), eye protection, gloves and long sleeved clothing.**

**Avoid breaking up waste material. Dispose of waste in sealed containers.**

**After handling, rinse exposed skin with water before washing gently with soap (not detergent). Wash work clothing separately.**

Before commencing any major repairs we recommend reference to the European Association representing the High Temperature Insulation Wool industry ([www.ecjia.eu](http://www.ecjia.eu))

### Health and Safety Information



Read all of the instructions in this booklet - including all the **WARNINGS** and **CAUTIONS** - *before* using this product. If there is any instruction which you do not understand. **DO NOT USE THE PRODUCT.**

### Safety Signs



#### **WARNING**

Indicates a potentially hazardous situation which, if not avoided, could result in death or personal injury.



#### **CAUTION**

Indicates a potentially hazardous situation which, if not avoided, could result in minor or moderate injury to the user or users, or result in damage to the product or to property.

#### **NOTE**

Indicates a potentially hazardous situation which, if not avoided, could result in damage or the loss of data.

### Equipment Operation

Use of this instrument in a manner not specified by Land Instruments International may be hazardous. Read **and understand** the user documentation supplied **before** installing and operating the equipment.

### Protective Clothing, Face and Eye Protection

It is possible that this equipment is to be installed on, or near to, machinery or equipment operating at high temperatures and high pressures. Suitable protective clothing, along with face and eye protection must be worn. Refer to the health and safety guidelines for the machinery/equipment before installing this product. If in doubt, contact Land Instruments International.

### Electrical Power Supply

Before working on the electrical connections, all of the electrical power lines to the equipment must be isolated. All the electrical cables and signal cables must be connected exactly as indicated in these operating instructions. If in doubt, contact Land Instruments International.

### Storage

The instrument should be stored in its packaging, in a dry sheltered area.

### Unpacking

Check all packages for external signs of damage. Check the contents against the packing note.

### Lifting Instructions

Where items are too heavy to be lifted manually, use suitably rated lifting equipment. Refer to the Technical Specification for weights. All lifting should be done as stated in local regulations.

## Contact Us

### UK - Dronfield

Land Instruments International  
Tel: +44 (0) 1246 417691  
E-Mail: [land.infrared@ametek.co.uk](mailto:land.infrared@ametek.co.uk)  
Web: [www.landinst.com](http://www.landinst.com)

### USA - Pittsburgh

AMETEK Land, Inc.  
Tel: +1 412 826 4444  
E-Mail: [irsales@ametek.com](mailto:irsales@ametek.com)  
Web: [www.ametek-land.com](http://www.ametek-land.com)

**For further details on all LAND/Ametek offices, distributors and representatives, please visit our websites.**

## Return of Damaged Goods

**IMPORTANT** If any item has been damaged in transit, this should be reported to the carrier and to the supplier immediately. Damage caused in transit is the responsibility of the carrier not the supplier.

**DO NOT RETURN** a damaged instrument to the sender as the carrier will not then consider a claim. Save the packing with the damaged article for inspection by the carrier.

## Return of Goods for Repair

If you need to return goods for repair please contact our Customer Service Department. They will be able to advise you on the correct returns procedure.

Any item returned to Land Instruments International should be adequately packaged to prevent damage during transit.

You must include a written report of the problem together with your own name and contact information, address, telephone number, email address etc.

## Design and Manufacturing Standards



The Quality Management System of Land Instruments International is approved to BS EN ISO 9001 for the design, manufacture and on-site servicing of combustion, environmental monitoring and non-contact temperature measuring instrumentation.



Approvals apply in the USA

**CE** This instrument complies with current European directives relating to Electromagnetic Compatibility 89/336/EEC and Low Voltage Directive 73/23/EEC.

Operation of radio transmitters, telephones or other electrical/electronic devices in close proximity to the equipment while the enclosure doors of the instrument or its peripherals are open, may cause interference and possible failure where the radiated emissions exceed the EMC directive.

The protection provided by both CE and IP classifications to this product may be invalidated if alterations or additions are made to the structural, electrical, mechanical or pneumatic parts of this system. Such changes may also invalidate the standard terms of warranty.

## Copyright

This manual is provided as an aid to owners of Land Instruments International's products and contains information proprietary to Land Instruments International. This manual may not, in whole or part, be copied, or reproduced without the expressed written consent of Land Instruments International Ltd.

Copyright © 2012 Land Instruments International.

**Contents**

1	Landcal Blackbody Source Type R1200P	1
2	Description	3
3	Specification	4
4	Electrical Supply details	6
5	Commissioning	7
6	Using the Furnace	9
7	Calibration of Radiation Thermometers	11
8	Maintenance	12
9	Eurotherm Temperature Controller Type 3216CC	16
10	Spares	18
11	Accessories	18
	Product Warranty	



# 1 Landcal Blackbody Source Type R1200P

## 1.1 Introduction

The LANDCAL blackbody type R1200P provides a temperature source for the on-site or in-laboratory calibration of radiation thermometers up to a temperature of 1200°C/2200°F. The source has been designed primarily for the calibration of short wavelength thermometers (Silicon Cell and Germanium detectors) but it can also be used for thermometers fitted with other types of detectors. However, when the calibration of longer wavelength thermometers are checked it is recommended that the calibration by comparison method is adopted.

Calibration is made by comparing the output from the thermometer under test with the target temperature.

The target temperature can be measured in 3 ways:

- 1) If traceability to national standards is not required, a check on the thermometer can be conducted by using the 'target' indication. From previous work, the target indication temperature has been found to agree with the radiance temperature to within  $\pm 10^{\circ}\text{C}$  at short wavelengths.
- 2) The temperature of the target can be measured by using a radiation thermometer of similar detector and optical characteristics, the calibration of which is traceable to national standards. This method of calibration can be described as calibration by comparison with a standard radiation thermometer.
- 3) Prior to supply, the relationship between the indicated target temperature and the true radiance temperature, as measured by a secondary standard radiation thermometer, will have been determined and reported in a traceable calibration certificate for the source. The temperature of the target is measured using the 'target' indicator and corrected for any errors as reported in the certificate.

A UKAS (United Kingdom Accreditation Service) Certificate of Calibration is available from LAND Instruments for either the source or the radiation thermometer.

## 1.2 Safety information

Every effort has been made during the design and manufacture of this furnace to ensure that it meets National and International standards of product safety. However great care should be shown by the user at all times when operating and maintaining high power furnaces which are capable of achieving high temperatures.

To reduce the risk of accident, follow the instructions listed below:

Warning



To avoid the possibility of electric shock, never expose the elements, terminals or other electrical components with the source connected to the mains supply. After completion of a repair, replace all safety plates before switching on the source.



To avoid the possibility of burns never attempt to dismantle the source until it has cooled to a safe temperature. This may involve an overnight wait.



This source contains no asbestos. The alumina-silicate (ceramic fibre) materials used release dust when disturbed which may, in some individuals, be an irritant to the skin, nose and throat.

### **Safety Note - Refractory Fibrous Insulation**

This product contains alumino silicate wool products in its thermal insulation. These materials may be in the form of blanket or felt, formed board or shapes, mineral wool slab or loose fill wool. Whilst there is no evidence of any long term health hazards, we strongly recommend that safety precautions are taken whenever the materials are handled.

**Exposure to fibrous dust may cause respiratory disease.**

**When handling the material always use an approved respiratory protection equipment (RPE-i.e. FFP3), eye protection, gloves and long sleeved clothing.**

**Avoid breaking up waste material. Dispose of waste in sealed containers.**

**After handling, rinse exposed skin with water before washing gently with soap (not detergent). Wash work clothing separately.**

Before commencing any major repairs we recommend reference to the European Association representing the High Temperature Insulation Wool industry ([www.ecjia.eu](http://www.ecjia.eu))

We can provide further information on request. Alternatively, our Service Department can quote for any repairs to be carried out, either at your premises or at Land Instruments International.

## 2 Description

The LANDCAL blackbody source type R1200P is a portable, self contained unit designed for use on any reasonably flat surface.

The 55mm/2.2 in diameter cylindrical target with conical end is manufactured from heat resisting steel. The temperature is measured by a thermocouple embedded into the target. The temperature is displayed on a digital indicator having  $\pm 1^{\circ}\text{C}/2^{\circ}\text{F}$  resolution.

The target is heated by radiant energy from a wound element. The source is fitted with a three term temperature controller which allows the source to heat up to  $1150^{\circ}\text{C}/2100^{\circ}\text{F}$  within 25 minutes and holds it stable at this temperature to within  $\pm 1^{\circ}\text{C}/2^{\circ}\text{F}$ .

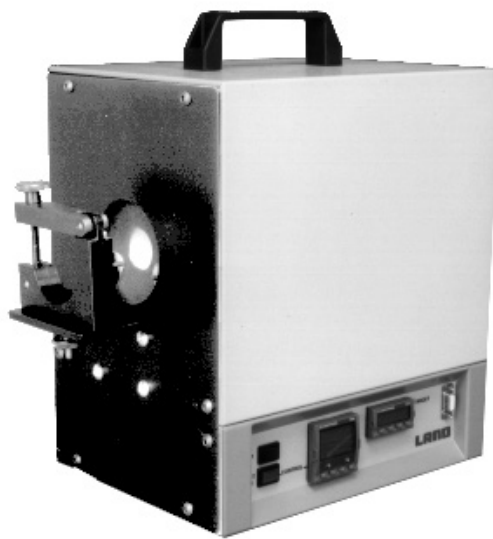

Fig. 1 Landcal Blackbody Source Type R1200P

CA970259

If the source is used as a transfer source (i.e. calibration by comparison method adopted) a set of optional standard radiation thermometers will be required. The selection of standards will depend upon customer requirements, e.g. working temperature range, type of radiation thermometers to be calibrated etc. Ideally, the standards should be of a similar type to those being tested, as strict comparisons can then be made. The standards listed below are recommended:

### System 4

Type M1 450/1000C:	Calibrated Temperature Range:	450 to 1000°C
Type M1 600/1600C:	Calibrated Temperature Range:	600 to 1200°C
Type M2 300/1100C:	Calibrated Temperature Range:	300 to 1100°C

### Portable

Cyclops 100:	Calibrated Temperature Range:	550 to 1200°C
--------------	-------------------------------	---------------

One standard should be returned each year to LAND Instruments for re-certification, or at any time when a discrepancy is detected.

### 3 Specification

Maximum working temperature:	1200°C (2200°F)
Recommended temperature range:	350°C to 1150°C (650°F to 2100°F)
Heating rate:	25 mins to 1150°C (2100°F)
Stability:	Radiance temperature variation $< \pm 1\text{K}$ ( $\pm 2^\circ\text{F}$ ) over a 60 minute period
Uniformity:	The temperature gradients across the middle 40mm of the 55mm cavity are within $\pm 1^\circ\text{C}$ over the temperature range 400 to 1150°C.
Radiation cavity	
Material:	Heat Resisting Steel (Kanthal APM)
Design:	Cylinder with 120° conical end
Inner diameter:	55mm (2.2in)
Internal length:	110mm (4.3in)
External aperture:	30mm (1.2in)
Emissivity:	Approximately 0.98 at short wavelengths
Themocouple type:	Both the Control thermocouple and Indicator thermocouple are Type N (NiSi/NiCrNiSi), mineral insulated, 3mm OD with Microbell B sheath, 350mm long plus 50mm tails.
Controller:	Eurotherm 3216 with RS 232 serial interface
Indicator:	Eurotherm 2132
Electrical supply*:	Externally selectable 115V a.c. or 230V a.c, 50 to 60 Hz. Part No. 135.192 100V a.c. or 200V a.c., 50 to 60 Hz Special
Power consumption:	1.1kW
Overall dimensions	
Height:	340mm/13.4in (400mm/25.4in) including handle)
Width:	300mm/11.8 in
Depth:	200mm/ 7.9 in
Weight:	8. kg (19.5lb)
Uncertainty (with UKAS Certificate	
400°C to 1100°C:	$\pm 3\text{K}$ (6°F)

- \* Always check that the supply voltage is compatible with the voltage on the furnace ratings label, and that the voltage switch (located on the underside of the source) is set correctly.

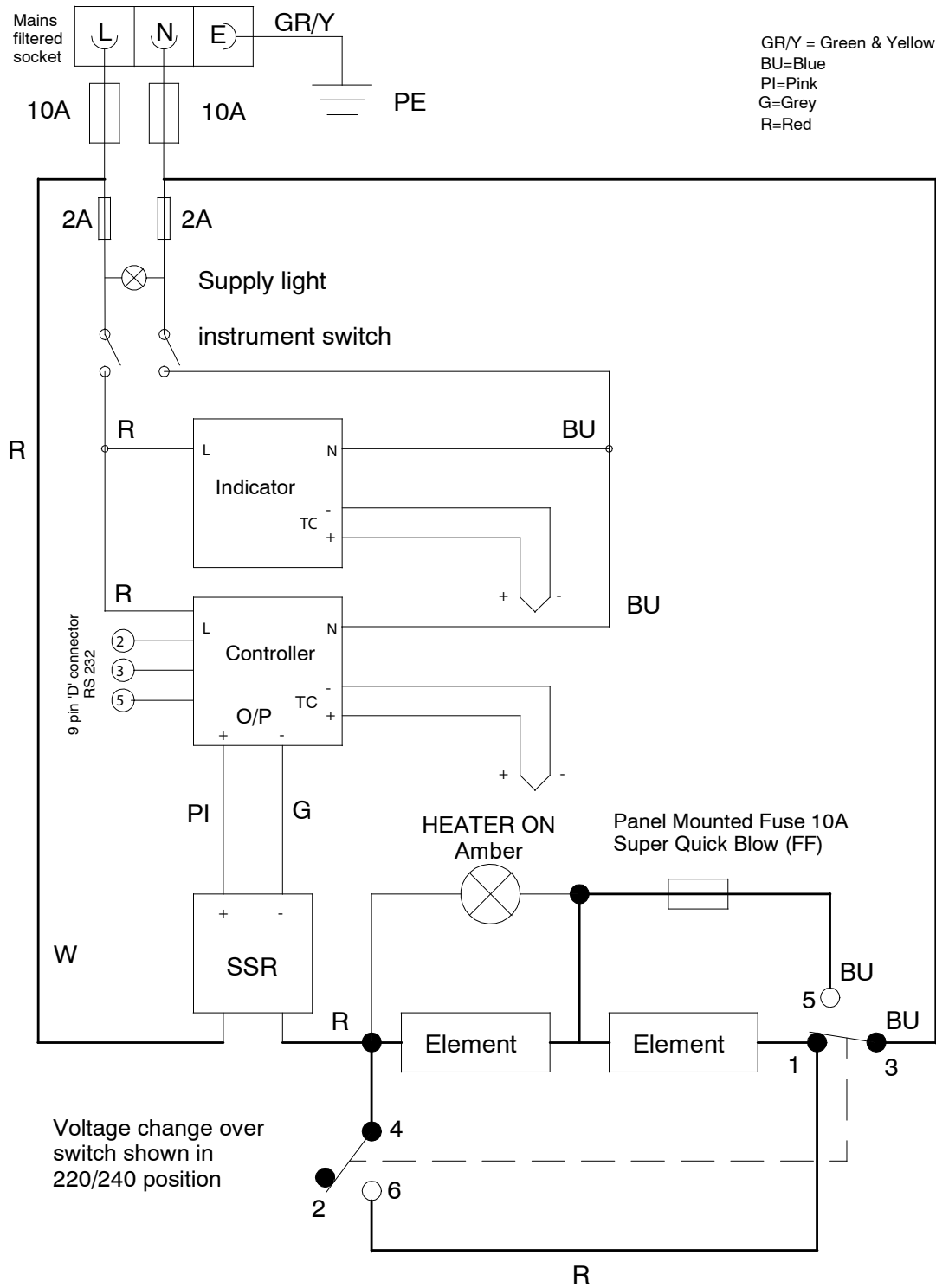

Fig. 2 Wiring diagram for the R1200P

CA970260

## 4 Electrical Supply details

### 4.1 Electrical connections

The furnace requires a single-phase a.c. supply with earth (ground). The supply may be Live to Neutral non-reversible, Live to Neutral with reversible plug, or Live to Live. Check that the supply voltage is compatible with the voltage on the furnace rating label, and that the voltage switch referred to above is set correctly.

The furnace is internally fused at 10 amps. A 110 to 120V supply must be fused externally at 10 amps. A 220 to 240V supply must be fused externally at 5 amps.

In the event of the furnace being used on 230V when the voltage switch is set to 115V, a fast-blow fuse will protect the circuit. This is located in a panel mounted holder adjacent to the voltage switch.



#### Note

The furnace is fitted with a supply cable which may be wired directly to an isolator which operates on both conductors, or fitted with a line plug which may be quickly disconnected from the supply. The isolator or the plug must be within easy reach of the operator. The supply **MUST** incorporate an earth (ground).

The wiring diagram for the R1200P is given in Fig. 2.

The power cable connection schedule is given in Table 1.

Cable Colour	Terminal Label	Supply Type Live-Neutral	Supply Type Reversible or Live-Live
Brown	L	To live	To either power conductor
Blue	N	To neutral	To the other power conductor
Green/Yellow	PE	To earth (Ground)	To earth (Ground)

Table 1 Power cable connection schedule

### 4.2 Fuses

Internal supply fuses: MK 1" 10A (2 off, internal)

Protection fuse\*: 20mm x 5mm HBC (FF) 10A (panel mounted)

\* to protect in case of connection to 230V with the dual-volt switch at 115V.1

To replace the protection fuse, use a screwdriver to remove the holder underneath the furnace. To access other fuses, remove the furnace back panel.

### 4.3 Earth leakage



#### Warning

Take care when operating the source with a residual current circuit breaker. At high temperatures, all ceramic materials become slightly conductive. This may mean that at temperatures above 1000°C a leakage current in excess of 30mA is present. This will cause an earth leakage trip switch to activate.

## 5 Commissioning

### 5.1 Inspection on receipt

Physically examine all items for damage that may have occurred during transit. Check the contents against the packing note.

If any item has been damaged in transit, this must be reported to the carrier and to the supplier immediately. Do not return damaged instruments to the sender as the carrier will not then consider a claim. Save the packing with the damaged article for inspection by the carrier.

### 5.2 Connections to the electrical supply

The a.c. supply cable has three cores. Connect the brown lead to live, blue to neutral and green/yellow to earth. When connected to the electrical supply and switched on the instruments will light.

**Warning**

At no time must any panels be removed when connected to the supply.

### 5.3 Heating up of the source

**Caution**

Ensure that there is free space around the source. Do not obstruct any of the vents in the control section, they are needed to keep the controls cool. When the source is operating at any temperatures above ambient, the front plate and case will become hot.

The source can be operated at any temperature in the range ambient to 1200°C (2200°F), however the recommended temperature range is 350°C to 1150°C (650°F to 2100°F). Set the controller to the required value as follows:-

- 1) When first switched on, the controller goes through a self check procedure. When this check is completed two displays will be visible.

Upper display	Actual element temperature
Lower display	Set point temperature

- 2) To modify the set point press, the 'Up' or 'Down' button until the required value is obtained.

The source will be ready for use at 1100°C/2000°F approximately 20 minutes after switch on.

The output light 'OP' indicates the state of the controllers output signal to the solid state relay which in turn switches the power to the heating element.

**Note**

All other controller parameters are factory set and locked. It should not be necessary to adjust them.

## 5.4 Using the RS232C Serial Interface Port

The source is supplied with a sub-miniature D-socket connected to the controller communication module to give RS232 serial communication. RS232 is suitable for direct connection to a personal computer (PC), using a cable configuration as shown below. The linked pins at the computer end are recommended, but may not be necessary.

The required cable is a 9-pin to connect to the furnace, and either a 9-pin or 25-pin to connect to the computer.

### RS232 Cable: Furnace to PC connections

Furnace end of cable - female		Computer end of cable - male		
<b>9-pin</b>		<b>9-pin</b>	(25-pin)	
<b>Rx 3</b>	_____	<b>3</b>	(2)	<b>Tx</b>
<b>Tx 2</b>	_____	<b>2</b>	(3)	<b>Rx</b>
<b>Com5</b>	_____	<b>5</b>	(7)	<b>Com</b>
		<b>7,8</b>	(4,5)	<b>Link together</b>
		<b>1,4,6</b>	(6,8,20)	<b>Link together</b>

The source is shipped with the RS232C communications protocol set to MODBUS, with the baud rate set to 9600 and no delay. The communication address is set to 1.

The source must only be connected and used with a PC by a person who understands how the serial communications function operates. If further information is required, either contact your local Eurotherm agent and request a copy of the Series 3000 Communication handbook, or consult the Eurotherm website.

## 6 Using the Furnace

### 6.1 Introduction

The furnace has been designed to create a target of uniform temperature with a high emissivity at short wavelength for calibrating mainly silicon cell and germanium detector radiation thermometers. The target is a conical cavity at one end of a hollow cylinder, and the thermometer views the target along the axis of the cylinder.

The cone plays an important part in establishing uniformity of radiation emitted by the target, and when calibrating radiation thermometers the target size requirements must be met by the cone. If the thermometer target size is so big that the walls of the cylindrical block are viewed, a less accurate calibration will result.

### 6.2 Measuring thermocouple/indicator

A thermocouple embedded in the conical target is used to measure the temperature. The "TARGET" digital indicator on the side of the furnace displays the temperature measured.

Agreement between the thermocouple measurement and a reference standard radiation thermometer should be better than  $\pm 10^{\circ}\text{C}$ .

The errors are repeatable, and a correction curve can be obtained with a Certificate of Calibration for the source. A UKAS (United Kingdom Accreditation Service (National Measurement Accreditation Service) Certificate of Calibration is available from LAND Instruments International.

### 6.3 Control thermocouple/controller

A second thermocouple is used to control the furnace temperature. As part of the control strategy, this thermocouple is situated close to the furnace heating elements. As a result the control thermocouple is actually hotter than the measurement thermocouple.

The setpoint on the furnace controller will invariably need to be set higher than the desired target temperature. The difference between setpoint and target temperature can be evaluated for a given furnace by experiment, always using the TARGET indicator as a measure of target temperature.

### 6.4 On-site use

The source is portable, so can be used either in the laboratory where the radiation thermometers are brought to the source for checking, or taken on-site where the source is used close to the thermometer installations.

Due to the lightweight construction of the source damage may occur if it is mishandled. The source should always be treated with respect and handled in the same way as any other scientific instrumentation. Following the precautions below will extend the life of the source.

- 1) Never subject the source to sudden impacts such as dropping.
- 2) Wherever possible store and carry the source in its accessory carrying case.
- 3) After use it is recommended that the source be left to cool to an internal temperature of 200°C before moving.
- 4) Never place the source into the carrying case whilst the external case is still hot, as this will melt the protective lining in the case.
- 5) Never insert objects into the cavity.

## 7 Calibration of Radiation Thermometers

An angle bracket is mounted onto the front plate of the furnace. A convenient method of holding a LAND fixed system thermometer is to use one of the optional holders which attach directly to the angle bracket.

Holder for System 3 Thermometers	Part N° 135.110
Holder for Fibroptic Thermometers	Part N° 135.109
Holder for System 4 Thermometers	Part N° 135.190

### 7.1 Preparation

The furnace control setting will usually be the normal working temperature of the thermometer to be tested.

The target temperature is that indicated by the measuring thermocouple displayed on the 'target' indicator.

### 7.2 Thermometer calibration

When the source is stable at the chosen control temperature, place the thermometer under test in the holder and measure the thermometer output on the measuring apparatus. Note the target temperature immediately.

### 7.3 Calibration procedures

When calibrating radiation thermometers it is important to follow documented step-by-step procedures to ensure that specified calibration conditions are met irrespective of operator. If difficulty is experienced in writing procedures, LAND will be pleased to offer guidance on the calibration of LAND products.

## 8 Maintenance

### 8.1 Routine servicing

The source is fully tested and evaluated before supply and should give years of trouble free operation if the precautions outlined in 6.4 and 8.4 are followed. No regular servicing or maintenance is required. The furnace outer surface may be cleaned with a damp cloth. Do not allow water to enter the case. Do not clean with organic solvents. In the unlikely event of a failure we would recommend the source is returned either to a LAND company direct or to one of the LAND distributors for repair. The instructions in Section 8.2 provide information for the customer replacement of the heating element and insulation.

### 8.2 Fitting a replacement heating element/insulation package

The location of the terminal blocks on the insulation assembly is shown in Fig. 3a.

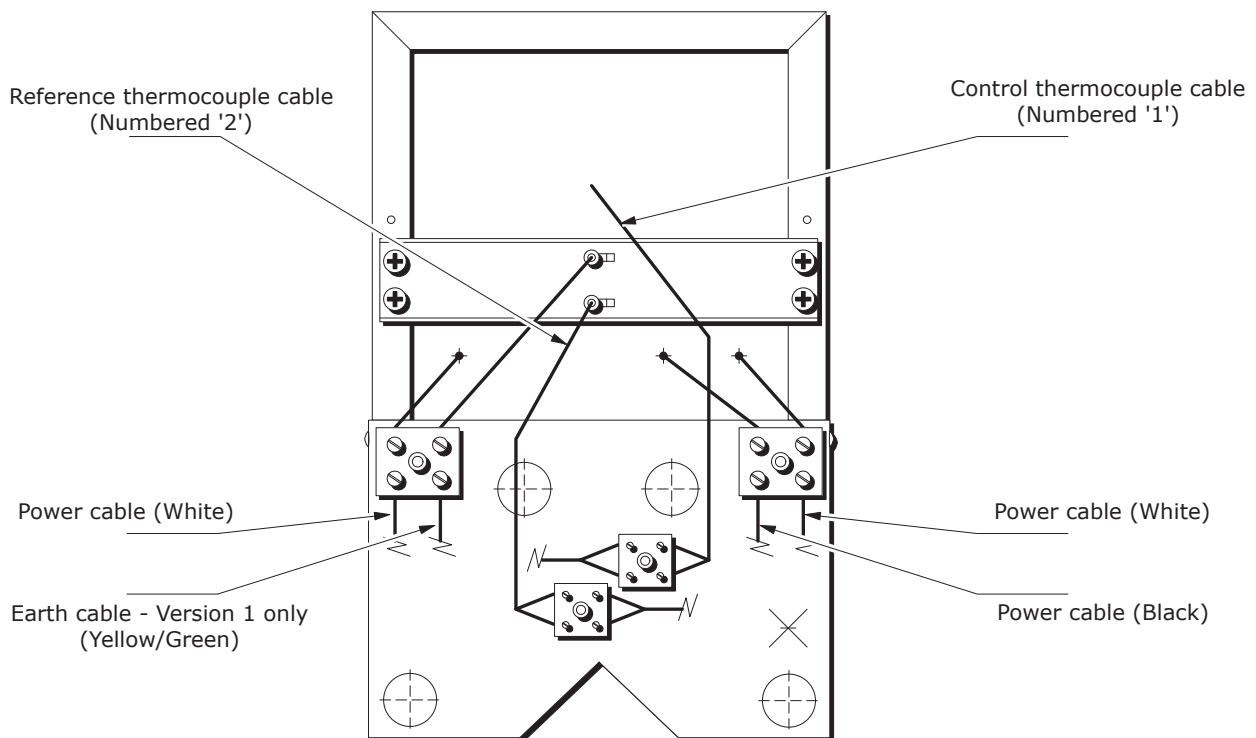

Fig. 3a Location of terminal blocks on insulation assembly (Rear View) CA970261a

The replacement assembly (Part Number 135.164) is supplied with the thermocouples in place. The assembly has undergone the standard test procedure to ensure the correct positioning of the reference thermocouple.

To remove the old insulation assembly:

- 1) Remove the front and back panels (7 screws each end).
- 2) Refer to Fig. 3a Disconnect the mains cable terminals from the terminal block.
- 3) Remove the top cover (3 screws on the left hand underside).

- 4) Disconnect the two thermocouple cables from the two thermocouple terminal blocks (note which cable is connected to which thermocouple).
- 5) The earth cable now needs to be disconnected.
  - (a) For version 1 sources (those manufactured up to and including 2003) the earth connection is as shown in Fig. 3a. Disconnect the earth cable from the earth terminal.
  - (b) For version 2 sources (those manufactured/repaired after 2003) the earth connection is as shown in Fig. 3b. Disconnect the earth cable from the target front support stud.
- 6) Disconnect the 3 power cables (2 white and 1 black) from the terminal blocks. Note which cable is connected to which terminal
- 7) Remove the insulation assembly from the base (4 set screws on the underside) complete with earth connection cable.

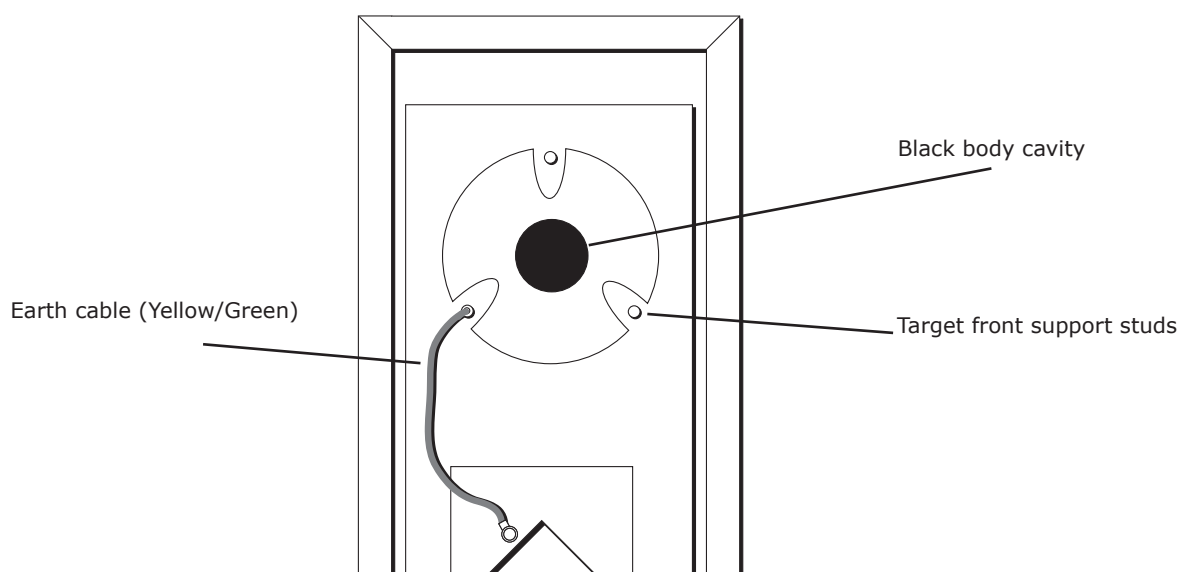

Fig. 3b Location of earth connection (Front View)

CA970261b

To fit a new insulation assembly:

- 1) Attach the insulation assembly onto the base using the 4 screws on the underside.
- 2) Connect the new earth cable to the earth terminal on the base.
- 3) Connect the 3 power cables (2 white and 1 black) to the large terminal blocks as shown in Fig. 3a.
- 4) Connect the two thermocouple cables to the two thermocouple terminal blocks (referring to the notes of which cable is connected to which thermocouple).
- 5) Attach the top cover using the 3 screws on the left hand underside.
- 6) Connect the mains cable terminals to the terminal block.
- 7) Attach the front and back panels using the 7 screws on each end.

### 8.3 Replacing the Solid State Relays

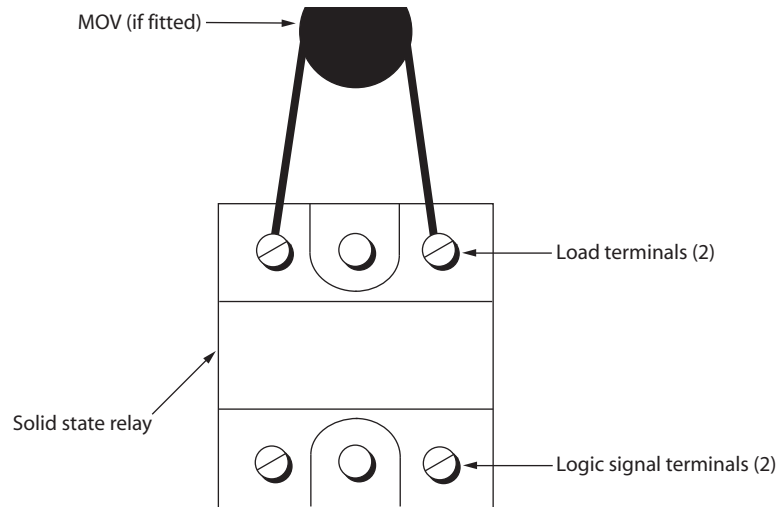

301013

Fig. 4 Solid state relay connections

- 1) Disconnect the furnace from the electrical supply.
- 2) Remove the rear panel from the furnace or control cabinet and locate the solid state relay(s), removing any other panels necessary to give reasonable access to the relay(s).
- 3) Disconnect the four or five wires, noting their numbers and positions.
- 4) Remove the faulty relay and replace it with a new one, noting which way round to fit it.

Original relays are fitted with a thin layer of 'off-white' paste to give good heat transfer to the aluminium sheet. New relays are supplied with a heatsink 'pad'. All remnants of the old heatsink paste must be removed. The thin white heatsink pad must be fitted between the solid state relay and the plate to which it is mounted.

- 5) Tighten the two fixing screws.
- 6) Refit the wires as noted in step 3. If the replacement solid state relay is supplied with a metal oxide varistor (MOV) it must be connected between the load terminals as shown in Fig. 12. It is not polarity dependent. The MOV protects the SSR from short periods of excess voltage. If the replacement SSR is supplied without an MOV this is because the MOV is built-in on later versions.
- 7) Replace the panels.
- 8) Reconnect the furnace to the electrical supply.

## 8.4 Safety Testing of Sources

- 1) After examination/repair, the source should always be safety tested before it is used for the routine calibration of thermometers. This safety testing should be carried out by a competent engineer. The results of the tests should be recorded.
- 2) Full Portable Appliance Testing (PAT) is not carried out on this source because some of the tests (such as flash tests) can damage semi-conductor components.
- 3) When the source is cold, carry out earth continuity checks. Check live to earth and neutral to earth. No continuity is expected. The measured resistance should be greater than 1Mohm.
- 4) Follow the earth continuity check with a function check. Switch on, set the temperature control to mid-scale. Monitor the rise in temperature. When the set point is reached, ensure that the source controls. Adjust the set point to the maximum temperature. Ensure that the source controls when the set point is reached.

## 8.5 Storage and carrying case

A custom built aluminium storage and transportation case is available as an optional extra. Use of this case is recommended when:

- a. The source is not in use.
- b. The source is hand carried to site.
- c. The source is carried to site in a motor car. Care should be exercised to ensure that the case is held firmly and does not move around excessively.
- d. The source is transported in an aircraft.

### NOTE

For additional protection of the source when transported in an aircraft, the case should always be packed in a thick cardboard carton with sufficient insulation material between the case and carton to absorb vibration and mishandling that may be experienced with airfreight transportation.

## 8.6 UKAS certification

To continue to carry out calibration checks which are traceable to National Standards, it will be necessary to obtain a Certificate of Calibration for either the furnace or standard radiation thermometer. UKAS Certification is available from LAND as an optional extra. Depending on usage the source and/or thermometer should be returned every 1 to 3 years for re-certification.

## 9 Eurotherm Temperature Controller Type 3216CC

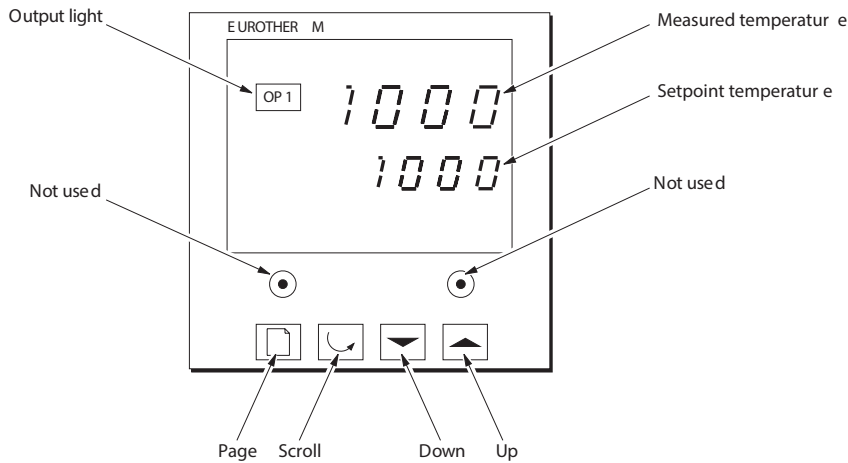

301014

Fig. 5 'Eurotherm' Controller - front panel controls

### 9.1 Introduction

When switched on, the controller lights up, goes through a short test routine, and then displays the measured temperature and starts to control. The output light glows or flashes as heating occurs.

In **Level 1** operation, both the setpoint temperature and the actual measured temperature are displayed.

The **Page** key allows access to the **Level 2** mode of operation. When in **Level 2**, the parameter lists within the controller can be displayed.

The **Scroll** key allows access to the adjustable parameters within the controller. Most lists and parameters are hidden and cannot be accessed by the operator even when in **Level 2** mode of operation. These hidden features contain factory-set parameters which should not be changed.

The **Up** and **Down** keys are used to alter the setpoint temperature in **Level 1** operation and parameter values when in **Level 2** operation.

To enter the **Level 2** mode of operation:

- 1) Press and hold the **Page** key for 3 seconds.
- 2) The display will show **Leu 1 Goto**. Release the **Page** key.
- 3) Press the **Up** or **Down** button to choose **Leu 2** (Level 2).
- 4) Press the **Up** or **Down** button to enter the Level 2 access code, which is **9**.  
The Home page is displayed.

The parameters within Level 2 are:

- 1) Press the scroll button. **WRK.OP** (working output) is displayed.
- 2) Press the scroll button. **SP.RAT** (setpoint rate limit) is displayed. This is set to **OFF**, but is adjustable.
- 3) Press the scroll button. **OP.HI** (maximum power output setting) is displayed. This is factory-set, but is adjustable downwards.
- 4) Press the scroll button. **ADDR** (communications address) is displayed. This is set to **1** and is adjustable.

- 5) Press the scroll button. **UNITS** (display units) is displayed. This is used to select °C or °F operation.

To return to the Level 1 mode of operation:

- 1) Press and hold the **Page** key.
- 2) Press the down key to select **Leu 1**.

## 9.2 Altering the Setpoint

- 1) Press either the **Down** or **Up** key once to display the setpoint.
- 2) Use the **Down** or **Up** key to adjust the setpoint value.  
The display returns to the measured temperature when no key is pressed for 0.5 seconds.

## 9.3 Altering the Ramp Rate

- 1) Press the **Scroll** key until **SP.RAT** (SetPoint ramp rate) is displayed.
- 2) Use the **Down** or **Up** key to adjust the ramp rate value.  
The ramp rate sets the maximum rate of heating or cooling in degrees per minute. A value of **OFF** cancels the ramp rate, allowing heating and cooling at the maximum rate. **OFF** is the default setting.

## 9.4 Altering the Power Limit (when applicable)

- 1) Press the **Scroll** key until **OP.Hi** (Output High) is displayed.
- 2) Press the **Down** key once to display the value of **OP.Hi ...and write down the value.**

Warning

Do not increase the value without correct calculation: the furnace elements or wiring could burn out.

- 3) To alter the value, use the **Down** or **Up** key. Do not set the value to zero: this will prevent the furnace from heating.

## 9.5 °C to °F Conversion

To change the controller from °C to °F operation:

- 1) Press the **Scroll** key until **UNITS** is displayed.
- 2) Use the **Down** or **Up** key to select the required units of measurement.

## 9.6 Altering the Communication Address

- 1) Press the scroll key until **Addr** (address) is displayed.
- 2) To alter the value press the **Down** or **Up** key.

The display returns to the measured temperature when no key is pressed for 45 seconds.

**Warning**

Do not alter any other parameters.

## 10 Spares

The following spare parts are available for use with the Landcal type R1200P.

<b>Description</b>	<b>Land Part Number</b>
Spare element/insulation package	135.164
Spare control or measuring thermocouple	135.172

## 11 Accessories

The following calibration accessories are available for use with the Landcal type R1200P.

<b>Description</b>	<b>Land Part Number</b>
Storage/carrying case	135.131
System 3 thermometer holder	135.110
System 3 fibroptic thermometer holder	135.109
System 4/Uno thermometer (inc fibroptic) holder	135.190
UKAS certification of Landcal R1200P (range 350 to 1200°C)	089.005

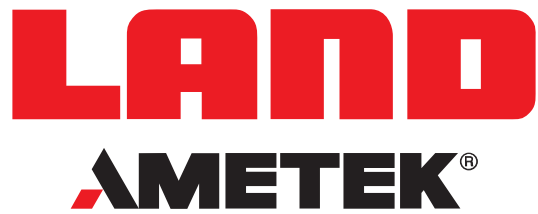

## PRODUCT WARRANTY

Thank you for purchasing your new product from Land Instruments International. This Land manufacturer's 'back-to-base' warranty covers product malfunctions arising from defects in design or manufacture. The warranty period commences on the instrument despatch date from the Land Instruments International Ltd. factory in Dronfield, UK.

### 36 MONTHS WARRANTY



Building upon the reputation for reliability and longevity that System 4 and UNO thermometers have earned, Land are delighted to be able to provide our customers with an industry-leading 36 month warranty for the following products:-

- SPOT thermometers, accessories\* and mountings\* and special instruments based on SPOT.  
*\*Note: SPOT Actuators are provided with an 12 months Warranty.*
- System 4 thermometers, processors, accessories and mountings and special instruments based on System 4.
- UNO thermometers, accessories and mountings and special instruments based on UNO.
- Application-dedicated processors based on LANDMARK® Graphic.
- ABTS/S and ABTS/U
- FTS
- VDT/S and VDT/U
- DTT
- FLT5/B
- 4500 MkIII (Transmissometer and AFU-APS-I/O only)
- LWIR Thermal Imaging Cameras
- NIR-B / MWIR-B Thermal Imaging Cameras

This 36 month warranty is provided as standard for all orders for the products listed above received from 1st May 2002.

We believe that our customers expect us to set the standard in terms of performance, quality, reliability and value for money. This 36 months warranty, as a part of an on-going program of continuous improvement, is just one way in which Land strive to maintain our position as the temperature measurement partner of choice.

### 24 MONTHS WARRANTY

The following Land Instruments International products are provided with a 24 months warranty:

- LSP-HD Linescanners
- NIR
- SDS-640

### 12 MONTHS WARRANTY

All other AMETEK Land products including NIR-B Camera Retraction and Mounting Systems, VIRALERT Human Body Temperature Screening Systems, Water Cooled Housings & Accessories, SPOT Actuator, and Air PurgeEquipment

# PRODUCT WARRANTY

## EXCLUSIONS FROM WARRANTY

---

It should be noted that costs associated with calibration checks which may be requested during the warranty period are not covered within the warranty.

AMETEK Land reserve the right to charge for service/calibration checks undertaken during the warranty period if the cause is deemed to fall outside the terms of the warranty

This Land manufacturer's warranty does not cover product malfunction arising from:-

- improper installation
- misuse
- unauthorised alteration
- inappropriate routing, support, physical shock & strain protection, etc. of the fibre-optic lightguide (where fitted)
- environmental conditions exceeding the IP / NEMA rating of the product
- inappropriate recalibration which results in product calibration being taken outside specification
- improper resealing of thermometer following parameter adjustment (UNO, FLT5/A, etc.)
- damage caused by an unauthorised repair
- consumables including filters, electrochemical cells, batteries and sorbents

Land Instruments International Ltd • Dronfield S18 1DJ • England • Tel: +44 (0) 1246 417691 • Fax: +44 (0) 1246 410585  
Email: [land.enquiry@ametek.com](mailto:land.enquiry@ametek.com) • [www.ametek-land.com](http://www.ametek-land.com)

AMETEK Land, Inc. • 150 Freeport Rd. • Pittsburgh, PA 15238 • U.S.A. • Tel: +1 (412) 826 4444  
Email: [land.enquiry@ametek.com](mailto:land.enquiry@ametek.com) • [www.ametek-land.com](http://www.ametek-land.com)

---

For a complete list of our international offices, please visit [www.ametek-land.com](http://www.ametek-land.com)

Issue 6: 15 June 2022