

# HOT ROLLING MILL

Infrared temperature measurement  
Application Information



# LAND

## SPECIALISTS IN NON CONTACT TEMPERATURE MEASUREMENT

LAND, acknowledged leaders in the field of radiation thermometry, have supplied the Steel industry throughout the world with temperature measuring equipment for over 55 years. Today, LAND manufacture a complete range of measurement equipment designed specifically for hot metal rolling applications. All are designed to the highest standards of quality and reliability to ensure accurate measurements in the harsh operating conditions of the hot mill.

LAND's reputation for quality products and service is attributable to good product design, to technical expertise and especially to extensive application knowledge. This knowledge has been gained by providing effective solutions to the varied problems of temperature measurement in the forming and rolling of hot metal.

Since the introduction of non contact thermometers into the modern hot rolling mill, their role has developed into providing a primary source of vital process information. They now fulfil three vital roles on the rolling mills of any modern steelworks.

### Product Quality

To ensure the finished product has gained the correct metallurgical properties the temperature must be closely monitored, not just in the finishing sections but throughout the process from casting to finishing.

### Product Uniformity

It is not sufficient to achieve the desired level of quality

for a single batch - once attained this level must be consistently maintained.

### Process Control

Whether control on the mill is manual or automatic, the control of critical temperatures is vital for the maintenance of quality, uniformity, throughput and energy consumption, and to ensure increased longevity of rolls and mill equipment.

Selection of the ideal thermometer is vital.

Provided careful consideration is given to not just the thermometer and signal processing requirements, but also the location, sighting and service requirements; long term, trouble free, accurate temperature measurement will result.

The information contained here highlights the locations, the recommended systems, their individual specifications and alternatives which are available. More detailed information is freely available from LAND.

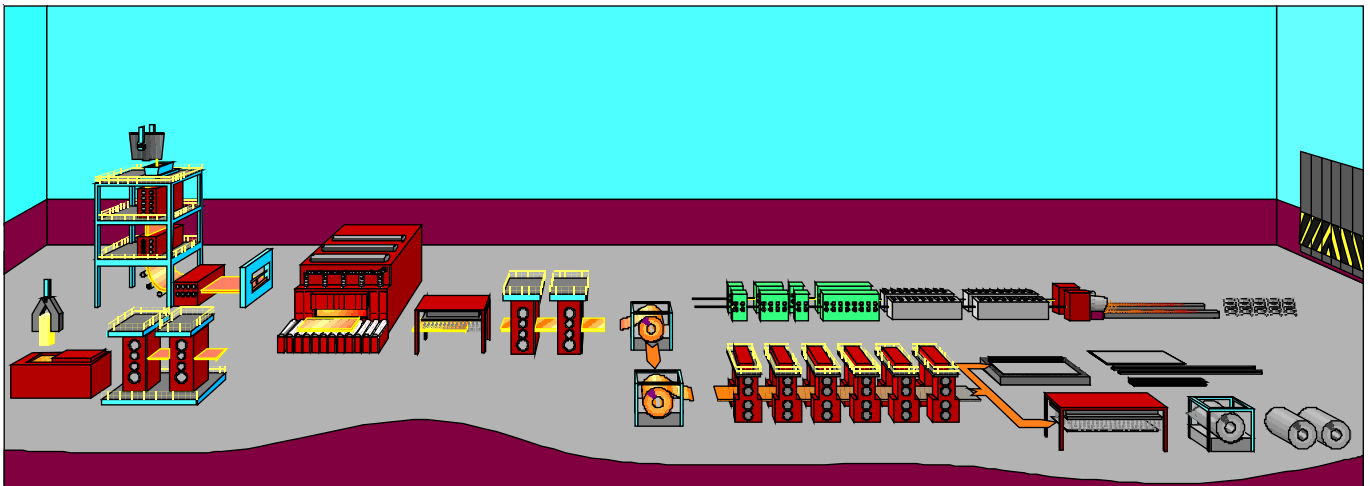

## WHY USE LAND NON CONTACT RADIATION THERMOMETERS?

- Radiation thermometers need no contact with the measured object, which means no contamination, interference or damage caused to the products or the equipment.
  - Flexibility in the choice of fixed, fibre optics systems or portable instruments to give comprehensive cover for all temperature needs.
  - Minimal maintenance and extended trouble free operation once correctly installed.
  - All Land Instruments International products are backed by BS EN ISO9001:2000 Quality Management System Approval and BS EN ISO/IEC 17025.
  - Accurate, reliable and stable measurement increases confidence in long-term product quality.
  - Traceability of calibration is to National Standards. Calibration certificates are available from our UKAS accredited calibration laboratory No.0034 in the U.K. and NIST (National Institute of Standards and Technology) in the U.S.A.
  - LAND know how, expertise and support - world wide.
- Also, a range of application dedicated products including Landscan infrared linescanners, Furnace Thermometers System (FTS) and Understrip Temperature Measurement System are aimed specifically at hot rolling mill applications.

## SELECTING THE THERMOMETER TO MATCH THE APPLICATION

MEASUREMENT N°. LOCATION	TYPE OF INSTRUMENT											
	FIXED THERMOMETERS & PROCESS IMAGERS								PORTABLE THERMOMETERS			
	LAND SCAN	STANDARD/FIBROPTIC THERMOMETERS							C53/153	C241	Furnace Pro	C300AF Mini's
M1/T.O. R1/R4/V1		M2/T.O.	M8	M6	FTS	SPRAY CHAMBER	USTS					
1 Concast/Spraychamber	•							•				
2 Concast withdrawal/ Straightening and exit	•	•							•			
3 Soaking pit	•	•							•			
4 Slabbing/Blooming Mill	•	•							•			
5 Reheat Furnace Charge				•								•
6 Reheat Furnace Load						•					•	
7 Reheat Furnace Exit	•	•							•			
8 Scale Breaker	•	•							•			
9 Roughing Mill	•	•	•						•			
10 Hot Coil box	•	•							•			
11 Finishing Mill	•	•							•			
12 Cooling Section	•		•							•		
13 Water Box	•		•									
14 Air Cooling/Laying Head	•	•							•	•		
15 Down Coiler	•		•		•				•	•		
16 Elec./Mech. Maintenance												•

The above table gives options for continuous on-line systems or portable spot instruments to meet your individual needs, and within both of these categories are flexible packages which can be field-tuned to your application.

### TYPICAL ELEMENTS OF A NON CONTACT RADIATION THERMOMETER SYSTEM

1. A high precision radiation thermometer which detects infrared energy emitted from the target surface and converts it into an electrical signal to be passed to the signal processor.
2. A high accuracy signal processor which linearizes the thermometer output signal and produces a signal suitable for interface with any indicating, recording or mill control equipment.
3. Some form of protection against the measurement environment. In a typical fixed system this would include a protection jacket giving water cooling and lens purging facilities, an end cap to provide environmental sealing, along with a mounting plate. Fibroptic thermometers do not require water cooling as they have the capability to withstand high ambient temperatures up to 200°C/392°F. The portable thermometers are self contained units protected by a durable jacket; they are supplied in a hard carrying case.



The schematics diagrams detailed on the following pages illustrate the principal features of a modern rolling mill. The areas highlighted offer measurement reference points, where LAND's radiation thermometry know-how can really benefit you. If the specific area of concern is not covered here our engineers will be pleased to discuss your requirements.

① **Continuous Caster - Strand Temperature Measurement in the Spray Chamber**

A very special thermometer is needed here to survive the hostile environment of the spray chamber without constant maintenance. Measurements using the Land Spray Chamber System allow cooling rates in the chamber to be optimised, directly influencing both product quality and process efficiency.

- Permits process/quality optimisation.
- Avoids break-outs.

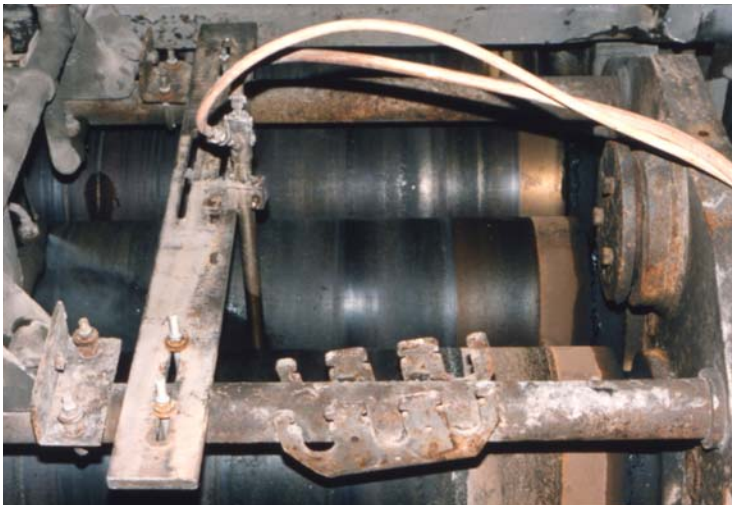

② **Continuous Caster - Withdrawal/Straightening and Exit**

Measurement at the withdrawal/straightening section or exit monitors process uniformity over several strands. Measurements made here can provide vital information on final stage cooling in the spray chamber to ensure uniformity. Installing on-line thermometer systems or Landscan linescanners here would:

- Provide information on cooling in the Spray Chamber.
- Check the temperature profile of the hot strand.

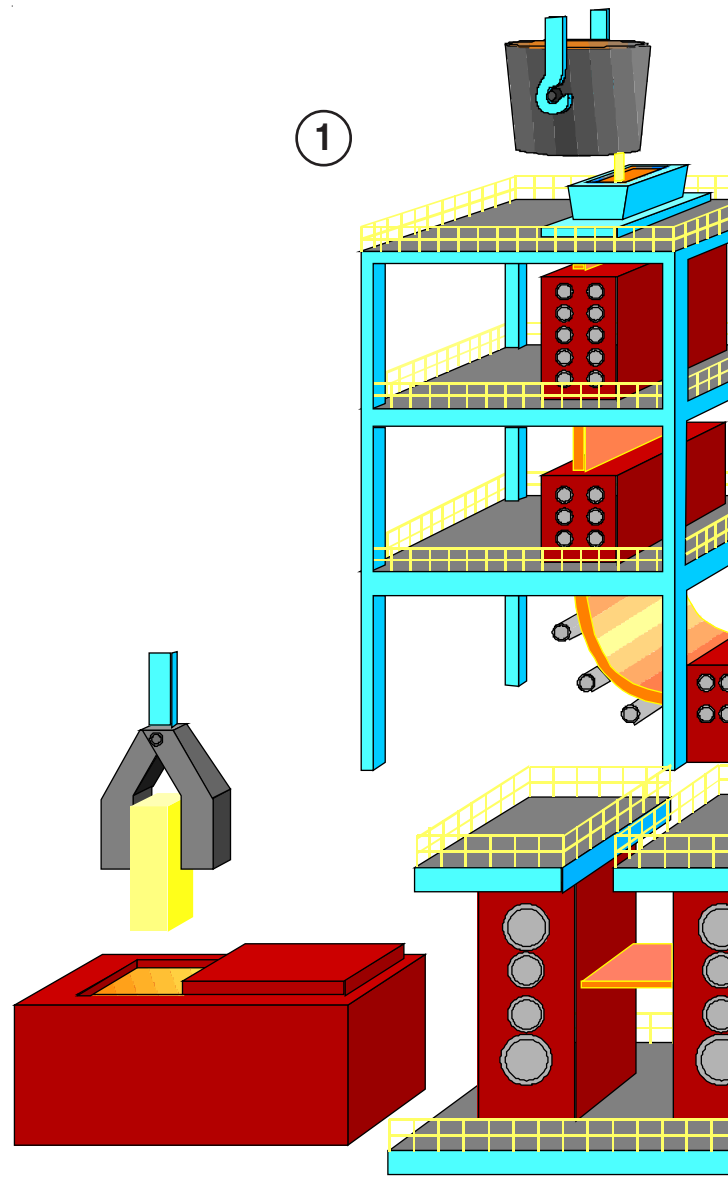

③ Soaking Pit

④

### ③ Soaking Pit -Load Temperature

The heating of the soaking pit is controlled using temperature measurements made at the end wall. Knowledge of the pit temperature and necessary soaking times can ensure that ingots leave the soaking pit at the correct temperature.

A Cyclops 153 portable thermometer can be used to periodically check both pit and ingot temperatures.

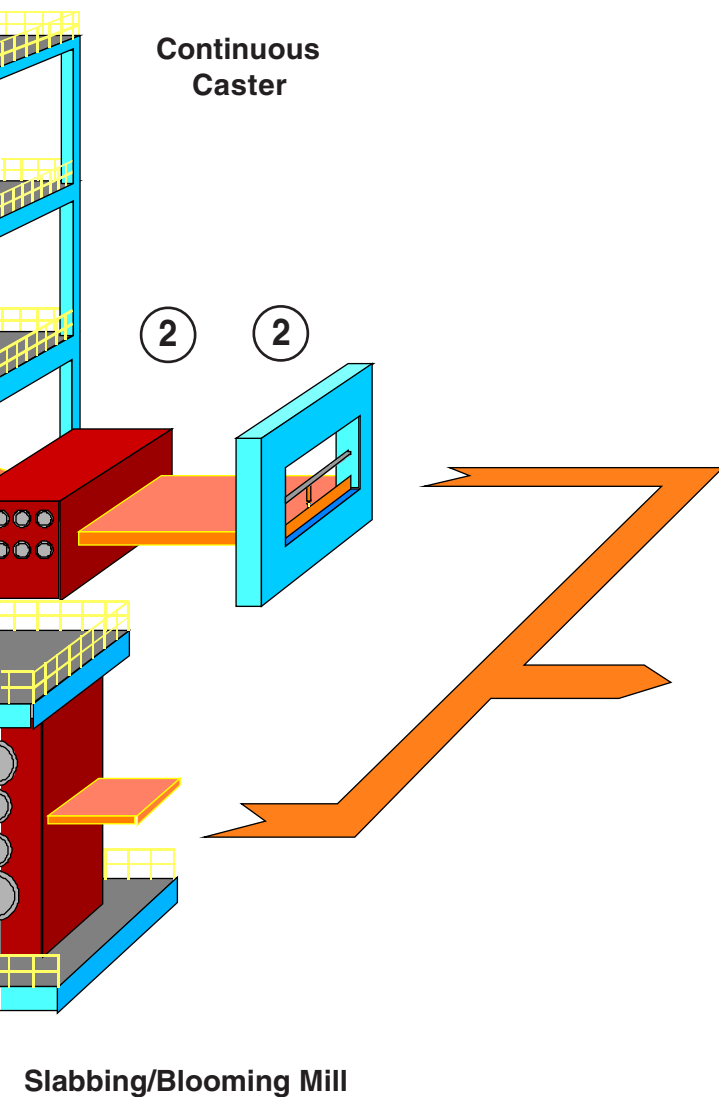

### ④ Slabbing/Blooming Mill - Billet Temperature Measurement

Temperature measurement at the exit of the mill is important. If the billet is too cold it needs to be put through the reheat furnace before entering the rolling section, otherwise a product with poor surface condition and metallurgical properties could result. A constant check using a short wavelength thermometer will:

- Provide ingot to billet temperature loss information.
- Give early warning of possible roll damage.



*Photograph courtesy of British Steel - Sections, Plates and Commercial Steels - Scunthorpe Works.*

### ⑥ Reheat Furnace - Load Temperature Measurement

Two sensors are used to determine true Reheat Furnace Load temperatures. A radiation thermometer, operating at  $3.9\mu\text{m}$  measures apparent load temperature and a furnace thermocouple or second  $3.9\mu\text{m}$  thermometer is used to measure furnace temperature. These two signals are fed into a Signal processing unit which computes true load temperature. The Furnace Thermometer System (FTS):

- Gives true stock temperatures, permitting optimised heating trajectories.
- Provides potential for substantial energy savings.
- Can be installed with minimum process disruption.



Photograph courtesy of British Steel - Sections, Plates and Commercial Steels - Scunthorpe Works.



### ⑤ Reheat Furnace Charge

Temperature measurement of the furnace charge allows adjustment of the furnace firing conditions in the pre-heat zone. Utilising a longer wavelength thermometer will help maximise reheating efficiency when either hot and cold charging.

### ⑦ Reheat Furnace Exit

The exit of the furnace represents the final opportunity to check the stock temperature before entering the mill.

Positioning a Landscan linescanner at the exit will determine temperature distribution i.e. poor uniformity will result in the need for burner adjustment. Landscan improves quality, reduces wastage of product, fuel and time.

A short wavelength thermometer with a LANDMARK Graphic signal processor using peak picking will give an accurate output avoiding errors due to surface scale. Used in conjunction with the charge and load measurements, it saves both time and fuel.

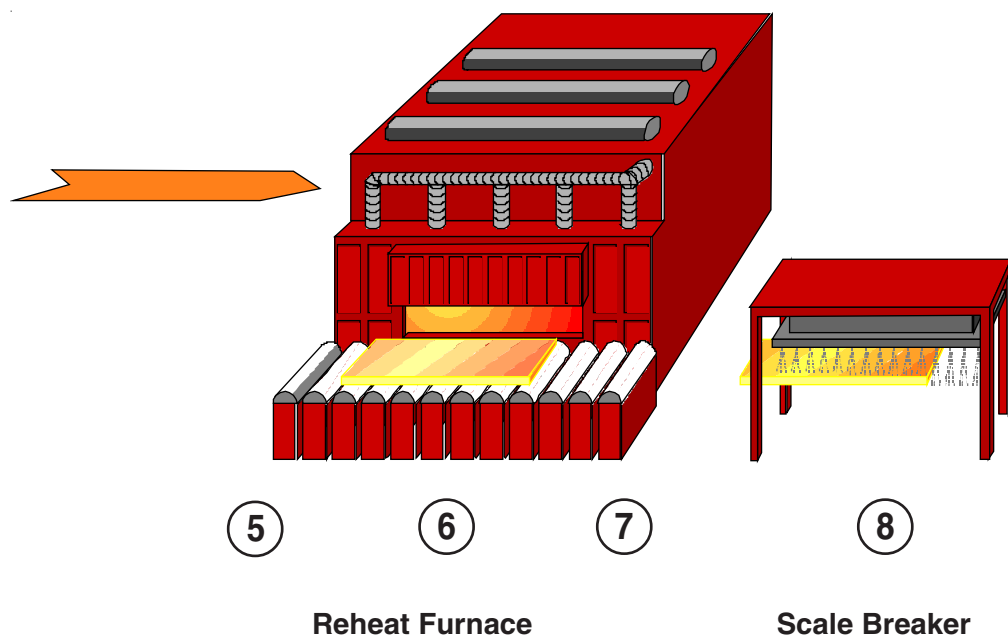

**⑨ Rolling Mill - Measurement at the Scalebreaker**

This provides the first opportunity to measure the temperature of the scale-free metal. Once the scale has been removed, thermometers measure the true surface temperature to ensure it is within rolling limits and to set mill parameters.

Utilising a short wavelength thermometer with a peak picker signal processing option allows the true metal temperature to be passed to mill control equipment.

Using a Landscan linescanner at this point will provide a two dimensional thermal map of the product.



**⑩ Rolling Mill - Coiler Temperature Measurement - Hot Coil Box**

Measurement of the strip, using a short wavelength thermometer or a Landscan linescanner, as it is uncoiled ensures that consistent rolling and finishing temperatures are maintained.

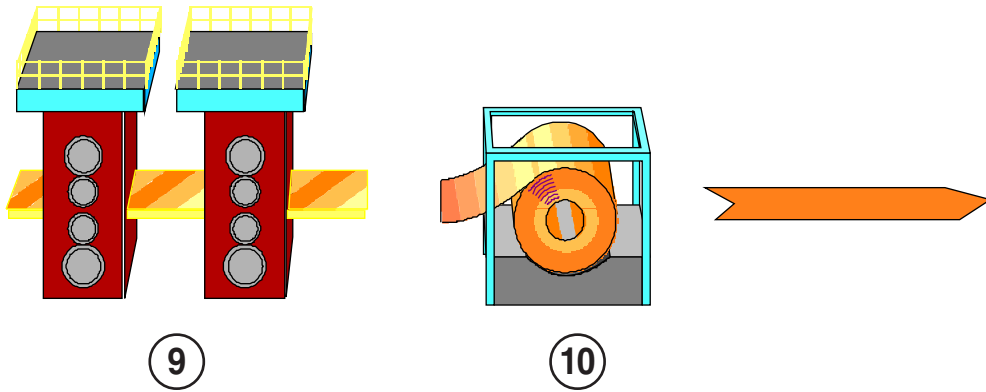

**Roughing Stands**

**Hot Coil Box (Hot Strip Mill)**



**⑨ Rolling Mill - Measurement at the Roughing Stands**

Measurements should be taken here at regular intervals to assist the operator in making the correct roll settings. This is essential if there are any stoppages so that roll parameters can be adjusted.

- Using a Landscan linescanner at this point will provide a two dimensional thermal map of the product.

Installation of a short wavelength thermometer:

- Gives the operator information or a mill computer data on which to set roll parameters.
- Can in addition be used as a hot metal detector.

**⑪ Rolling Mill - Finishing Stands Temperature Measurement**

It is essential to know the temperature of the finished product to ensure that the correct metallurgical properties have been obtained.

Installation of an on-line thermometer system or a Landscan linescanner provides the vital temperature information required for the cooling sections.



Photograph shows a typical installation of a Landscan sensor head.

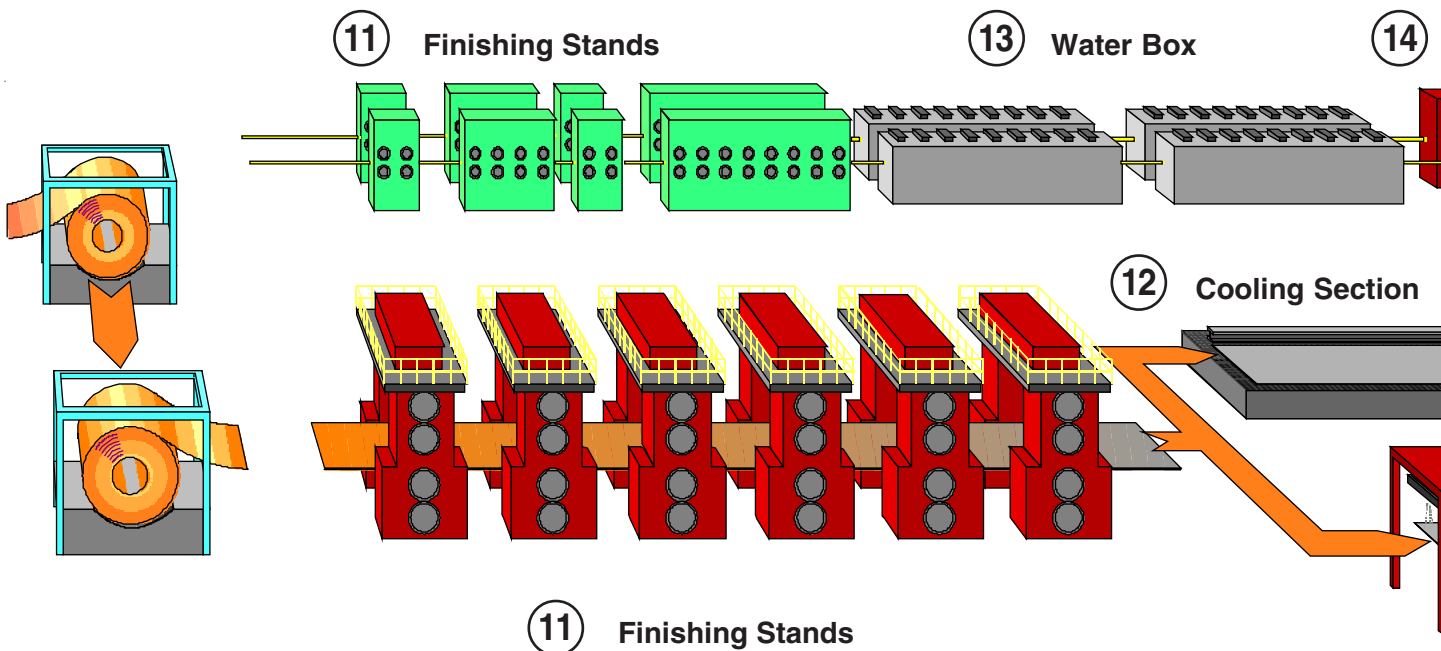

**⑫ Rolling Mill - Measurement at the Cooling Section/Runout Table**

The thermal sensitivity of some metals means that monitoring must take place to avoid damage or stresses occurring. It is therefore equally important to maintain high accuracy temperature measurements at the cooling section to benefit the overall quality of the finished product, and to realise the correct properties.

Installing a Landscan linescanner at the cooling exit ensures maintenance of product quality throughout the cooling cycle.

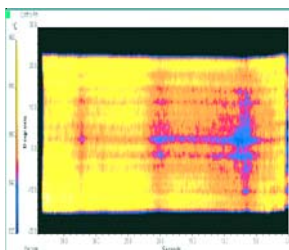

An Understrip Thermometer System USTS can be used to provide a centreline measurement of the underside of the strip on the runout table.

A two-dimensional thermal map.

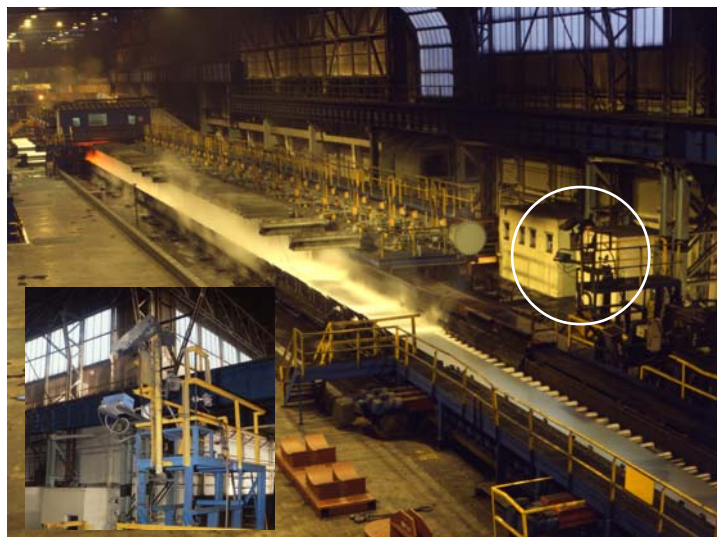

**13 Wire/Rod Mill - Measurement at the Water Box (not illustrated)**

Cooling here needs to be rapid but controlled to ensure metallurgical properties are retained. Insufficient cooling would result in out of specification material, i.e. scrap or downgrade.

Installation of a ratio or target-orbiting (T.O.) thermometer :

- Allows continuous measurement.
- Provides control to the water spray coolers to retain metallurgical properties.
- Permits a range of rod/bar diameters to be monitored.



Photo courtesy of Hoesch Hohenlimburg AG.

**15 Rolling Mill - Temperature Measurement at the Down Coiler**

Measurement prior to the down coiler using either a Landscan linescanner or a short wavelength thermometer provides feedback on product temperatures to build up quality control data.

- A Landscan linescanner provides analog zone outputs for controlled cooling of the strip.

Where there is a requirement for direct rolling of high performance 'dual phase' steels for crash energy-absorbing automotive components, use of an Under Strip Thermometer System (USTS) utilising a M3 thermometer provides a high degree of confidence that the required structure is consistently achieved throughout each coil.



Laying Head

**14 Cooling Conveyor**

Finished Product

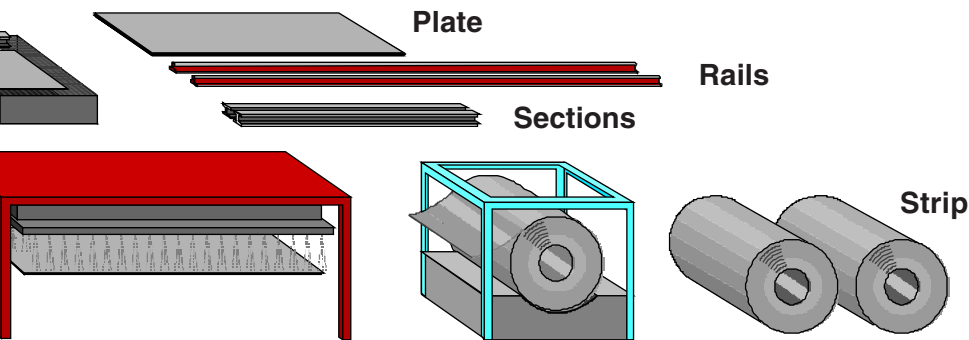
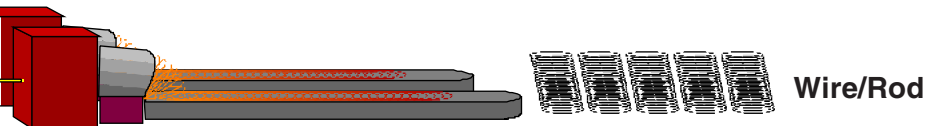

**12 Cooling Section**

**15 Down Coiler**

**14 Wire/Rod Mill - Measurement at the Laying head and on the Air Cooling Conveyor**

Temperature measurement using either a Landscan linescanner, a ratio thermometer or a target-orbiting (T.O.) thermometer in the air cooling zones is vital to ensure both metallurgical structure and hence mechanical properties are retained in the finished product.

On-line measurement should be made in both the laying and cooling zones so that control in each can be effected.

In addition a Landscan linescanner provides:

- Complete two-dimensional thermal mapping of the laid products.

A Cyclops 153 can be used to monitor laying head temperatures, and a Cyclops 241 for cooling conveyor temperatures.



## BRIEF OUTLINE SPECIFICATIONS

TYPE	MODEL	TEMPERATURE RANGE	SPECTRAL RESPONSE	FOV	ACCURACY (UNCERTAINTY)
LINESCANNER	LANDSCAN	For full description and specification refer to Landscan datasheet LS100			
STANDARD AND FIBROPTIC THERMOMETERS	M1/T.O.	450 to 1000°C/850 to 1850°F 600 to 1600°C/1100 to 2900°F 800 to 2600°C/1500 to 4700°F	1.0µm	30:1 100:1 200:1	≤0.4%K ≤0.4%K ≤0.7%K
	M2/T.O.	300 to 1100°C/600 to 2000°F	1.6µm	100:1	≤0.25%+1K
	M6	0 to 300°C/50 to 600°F 100 to 700°C/200 to 1300°F	3 to 5µm	30:1 100:1	0.3% + 2.5K 0.3% + 2K
	M8	0 to 1000°C/30 to 1830°F	8 to 14µm	100:1	<1%K+1K
	R1/V1	600 to 1600°C/1100 to 2900°F 1000 to 2600°C/1800 to 4700°F	0.85 to 1.1µm	50:1 200:1	0.65% K 1.1% K
	R4	250 to 500°C/500 to 950°F 300 to 600°C/600 to 1100°F	N/A	30:1	±5°C / 9°F
PORTABLE THERMOMETERS	CYCLOPS 53 CYCLOPS 153/153A	500 to 3200°C/930 to 5800°F 600 to 3000°C/1100 to 5500°F	0.8 - 1.1µm	8°	±0.5% ±1 digit
	CYCLOPS 241	250 to 800°C/500 to 1470°F	1.1 to 1.7µm	9°	>300°C/570°F ±1% <300°C/570°F ±4%
	Mini View+	-50 to 500°C/-50 to 950°F	8 to 14µm	1.4° & 2°	±1% ±1 digit
	CYCLOPS 300AF/bAF	-50 to 1000°C/-50 to 1800°F	8 to 13µm	8°	>200°C/390°F ±1% ±1 digit <200°C/390°F ±2°C/4°F ±1 digit
	POCKETHERM 30,30A,31	-40 to 400°C/-40 to 750°F (30/30A) -50 to 500°C/-50 to 950°F (31)	8 to 14µm		-
	FTS	500 to 2000°C/900 to 3600°F	3.9µm	100:1	<2K
APPLICATION DEDICATED	SPRAYCHAMBER M1, R1 SPRAYCHAMBER M2	600 to 1600°C/1100 to 2900°F 300 to 1100°C/600 to 2000°F	1.0µm; 0.85 to 1.1µm (R1) 1.6µm	25:1 nominal	≤0.4%K, ≤0.25%+1K
	USTS	Several ranges, measurements from 50°C upwards	various, application dependent	various	various, application dependent

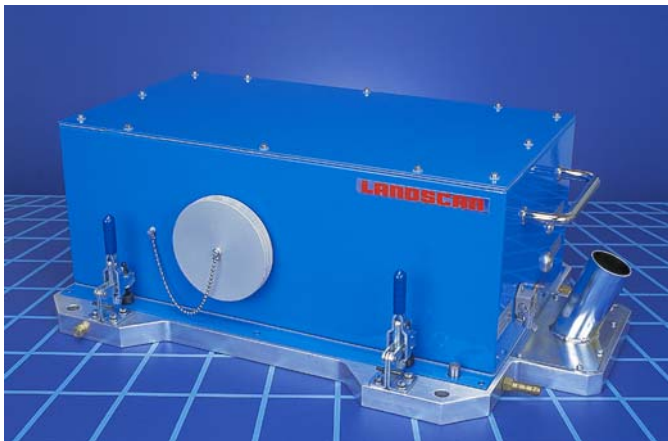

## ◀ LANDSCAN

Landscan is a series of infrared linescanning systems designed specifically for use in the hostile environment of the hot rolling mill.

Landscan measures a thermal profile across a hot object which generates and displays two dimensional temperature profiles using the latest Landscan WCA software. The entire system, including scan speed (100Hz), emissivity and outputs can be adjusted to suit individual requirements.

- Choice of 6 sensor heads for different application.
- Choice of 6 optical variants for accurate sighting onto target.
- Adjustable scan rate 5 to 25 scan/sec.

## PORTABLE THERMOMETERS ▶

The Land Cyclops family of high quality portable infrared thermometers provides precision spot temperature measurement with unmatched accuracy and reliability.

Features such as precise view of target spot with simultaneous digital display of temperature in the viewfinder, choice of operating and calculating modes, digital output and out of range alarm are provided.

There are also models which incorporate a laser targeting system to accurately pinpoint the measurement spot.

Optional data processor, data logger and digital printer are also available which greatly expand the measurement and data analysis capabilities of Cyclops.



RESPONSE SPEED	REPEATABILITY	PROCESSOR/ OUTPUTS SUPPORTED	OPTIONS/ SPECIAL FEATURES	LITERATURE CODE
For full description and specification refer to Landscan datasheet LS100				LS100
5ms to 95%	<1K	Landmark processors LMB, LMC, LMG, LMP, LMT; 0/4-20mA, mV/°, Hi/Lo Alarms, RS232C, RS485, Profibus DP	Fibroptic versions, Target Orbiting versions, close-up lenses, optics, temperature ranges, laser targetting, intrinsically safe, Understrip, Fibroptic versions rated to 350°C/660°F	S4T
5ms to 98%	<1K		S4T	
100ms to 98%	<1K 1K		Close-up lenses, optics, temperature ranges, laser targetting, intrinsically safe	S4T
100ms to 98%	<1K		Optics, temperature ranges, laser targetting, intrinsically safe	S4T
15ms to 98%	1K 2K		Fibroptic versions (to 350°C/660°F), optics, laser targetting, temp. ranges, intrinsically safe	S4T
1s to 98%	<1°C/2°F at 400°C/ 800°F (ε=0.1)	LMG RP4 0/4-20mA, 2 x Hi/Lo alarms, RS232C, RS485	Focus distances, higher temperature ranges	S4T
0.6s (98% response) 0.45s (98% response)	±0.15% (C153) ±0.1% (C53)	Cyclops Data Processor/Logger RS232C format (153, 153A), 1mV/° (153A)	Close-up lenses, heat protection, data processor/logger	C105
0.3 to 0.6s	±2°C/4°F			C105
0.5s	±0.5°C/1°F			CML+
0.5s (to 90%)	±1°C/2°F to infinity			C105
1.5s (to 90%)	<1°C/2°F			PDS PT
100ms to 95%	<2K	LMG-M 1100-2 (single furnace zone) LMG-M 1111-2 (dual furnace zone)	N/A Optics, temperature range	ADS003
5ms, 15ms (R1) 5ms		LMG in 'peak sample' mode, 0/4-20mA, mV/°, Hi/Lo Alarms, RS232C, RS485	Optics, fibroptic lengths, stand alone version laser targetting, transportable versions	
various, application dependent		LMB, LMC, LMG, LMP, LMT, 0/4-20mA, mV/°, Hi/Lo Alarms, RS232C, RS485, Profibus DP	Optics, wavelengths, temp ranges, standalone versions, Fibroptic versions (to 350°C/660°F) Dual USTS probes	

## STANDARD & FIBROPTIC THERMOMETERS

The System 4 fixed, on-line range operates as a three part system incorporating a high precision standard or fibroptic thermometer, a LANDMARK® signal processing unit and a full range of protection jackets, mountings and purges.

The standard thermometers offer different temperature ranges and focusing distances to provide a choice of measurement spot sizes and working distances.

The fibroptic thermometers incorporates three separate parts, the optic head, the light guide and the amplifier which is linked to a LANDMARK signal processor.

The use of fibre optics enables the detector and electronics to be located in an area where the ambient temperature is lower than that encountered at the measuring point, eliminating the requirement for water cooling of the thermometer at the measurement point. The lens head and fibre optics can withstand high ambient temperatures - up to 200°C/400°F as standard and up to 350°C/660°F to special order.

Also, fibre optics allow access to a target surface which might otherwise be inaccessible or in a hostile location.



The Uno range of 'stand alone' standard and fibroptic thermometers offer a choice of built in time functions, peak picker or averager and a range of temperature spans and operating wavebands to ensure optimum accuracy of measurement.



## APPLICATION DEDICATED

A range of thermometer systems have been designed to fulfil specific functions on the modern hot rolling mill.

All have proven success in their specialist roles attaining high levels of performance, reliability, flexibility and durability in their specific application areas.

They include the Furnace Thermometer System, the Spray Chamber System and the Understrip Thermometer System.

For more than fifty five years LAND has supplied temperature measuring systems and instruments to many different industries all over the world. Now the world leader in non contact thermometry, our expert advice and support is never far away.



## WORLD LEADERS

LAND is one of the world leaders in the manufacture of non contact temperature measurement systems, thermal imagers and linescanners.

## WORLDWIDE SUPPORT

In addition to the companies established in the USA, Europe, Mexico and Japan, LAND is represented by distributors in most of the major industrial countries throughout the world.

Our customers benefit, on a global basis, from practical and expert advice from fully trained technicians who are aware of specific requirements for their country and industry.

## APPLICATIONS

LAND has solved many different temperature measurement problems in a wide variety of industries from food to atomic energy, some of which are listed below:

- Iron & Steel
- Petrochemical
- Heat Treatment
- Minerals
- Glass
- Maintenance
- Power & Utilities
- Aerospace
- Electronics
- Pharmaceuticals
- Plastics
- Paper
- Rubber
- Textiles
- Non-ferrous Metals

For further information or free advice on specific temperature measurement problems within these or any other industry, contact your nearest Land office.

## PRODUCT ASSURANCE

When you specify LAND products you are assured of receiving a completely pretested, calibrated working product. Each instrument is carefully checked to ensure complete compliance with specification and is fully guaranteed. LAND was the first manufacturer of infrared instruments to successfully obtain ISO 9001 Quality Management System Approval for both design and manufacture of non contact infrared temperature measuring equipment.

 These products comply with current European directives relating to electromagnetic compatibility and safety (EMC directive 89/336/EEC; Low voltage directive 73/23/EEC).

The Quality Management System of Land Instruments International Ltd. is approved to BS EN ISO9001:2000 for the design and manufacture, stockholding, in-house repair and site servicing of non contact temperature measuring instrumentation. Associated software designed and developed in accordance with TickIT. Calibration certificates are available from our UKAS accredited Calibration Laboratory No. 0034. The Land calibration laboratory complies with the requirements of the international standard BS EN/IEC17025.

## CALIBRATION

LAND operates an extensive calibration service. All calibrations made are traceable to National Standards. In the USA a traceable calibration certificate can be issued complying with the National and International Standards. In the UK, LAND can issue a UKAS calibration certificate.

LAND also supplies a full range of temperature reference sources which are used to verify or re-establish the accuracy of calibration in the field or in the laboratory.

A consultancy service is also available for those companies who wish to establish their own in-house calibration facility.



0034

# LAND

instruments international

Infrared Temperature Measurement

Land Instruments International • 10 Friends Lane • Newtown, PA 18940-1804 • U.S.A. • Tel: (215) 504-8000  
 Fax: (215) 504-0879 • Email: [irsales@landinstruments.net](mailto:irsales@landinstruments.net) • Internet: [www.landinstruments.net](http://www.landinstruments.net)

Land Instruments International • Dronfield S18 1DJ • England • Tel: (01246) 417691 • Fax: (01246) 410585  
 Email: [infrared.sales@landinst.com](mailto:infrared.sales@landinst.com) • Internet: [www.landinst.com](http://www.landinst.com)

**France**  
 Land Instruments Sarl  
 Tel: (1) 34 62 05 45 • Fax: (1) 30 56 51 12  
 Email: [commercial@landinst.fr](mailto:commercial@landinst.fr)

**Japan**  
 Land KK  
 Tel: 06 6330 5153 • Fax: 06 6330 5338  
 Email: [ikeland@silver.ocn.ne.jp](mailto:ikeland@silver.ocn.ne.jp)

**Germany**  
 Land Instruments GmbH  
 Tel: 02171/7673-0 • Fax: 02171/7673-9  
 Email: [infrarot@landinst.de](mailto:infrarot@landinst.de)

**Spain**  
 Land Instruments International  
 Tel: 91 630 0791 • Fax: 91 630 2918  
 Email: [land-infrared@landinst.es](mailto:land-infrared@landinst.es)

**Italy**  
 Land Instruments Srl  
 Tel: 02/99040423 • Fax: 02/99040418  
 Email: [infrared@landinst.it](mailto:infrared@landinst.it)

**Mexico**  
 Land Instruments International  
 Tel: 52 55 9171 1466 • Fax: 52 55 9171 1477  
 Email: [ventas@landinstruments.net](mailto:ventas@landinstruments.net)